

ALTOS

an Acer Group Company

Altos

工作站/Workstaion

S25E1

BrainSphere™ P330 F6 SE

使用手冊

Revision 1.0

本使用手冊中的資訊已仔細審核，並被認為準確無誤。供應商對本文檔中可能包含的任何不準確之處不承擔任何責任，亦不承諾更新或維持本手冊中資訊的時效性，亦不承諾將更新內容通知任何個人或組織。請注意：如需取得本手冊的最新版本，請造訪我們的網站

<https://www.altoscomputing.com>.

Altos Computing Inc.（簡稱 Altos）成立於 2017 年，是宏碁 (Acer Inc.) 旗下子公司。Altos 的業務模式是透過內部研發與 ODM/IHV/ISV 合作，在伺服器、工作站、瘦客戶端、網路和儲存領域提供最精簡、最具成本效益的整合解決方案。在追求極致速度的時代，Altos 提供領先的解決方案，包括但不限於高效能運算、虛擬桌面基礎架構、雲端基礎架構和軟體定義儲存等。

FCC 聲明：本設備已通過測試，符合 FCC 規則第 15 部分關於 A 類或 B 類數位設備的限制規定。這些限制旨在為設備在工業環境中（A 類設備）或住宅環境中（B 類設備）運作時提供合理的保護，防止其受到有害幹擾。本設備會產生、使用並輻射射頻能量，若未依照製造商的說明手冊進行安裝和使用，可能會對無線電通訊造成有害幹擾。在住宅區操作本設備可能會造成有害幹擾，在這種情況下，您需要自行承擔消除乾擾的費用。



除非您要求並獲得 Altos Computing, Inc. 的書面許可，否則不得複製本文檔的任何部分。本文檔中的資訊如有變更，恕不另行通知。本文提及的其他產品和公司是其各自公司或商標持有人的商標或註冊商標。

Copyright © 2025 by Altos Computer, Inc. All rights reserved.

Printed in the Taiwan

Conventions

The following conventions are used in this user's guide:

	NOTE! 提供與當前主題相關的一些附加資訊。
	CAUTION! 提供預防措施，以避免可能出現的硬體或軟體問題。
	WARNING! 提醒您執行或不執行特定操作可能造成的任何損害。

警告和注意事項

安裝前，請務必了解以下警告和注意事項。



WARNING!

為降低觸電或設備損壞的風險，請注意以下事項：

- 請勿停用電源線接地插頭。接地插頭是一項重要的安全功能。
- 將電源線插入易於插拔的接地電源插座。
- 拔除所有電源插頭上的電源線，以斷開設備電源。
- 觸電危險！維修前，請斷開所有電源線。
- 請勿將電源線佈置在容易被踩踏或物品夾住的地方。請特別注意插頭、電源插座以及電源線從伺服器延伸出來的位置。



WARNING!

為了降低因高溫表面而造成人身傷害的風險，請讓驅動器和內部系統組件冷卻後再觸摸它們。



CAUTION!

請勿在檢修面板開啟或拆卸的情況下長時間操作系統。以這種方式操作系統會導致氣流不暢和冷卻不良，從而可能造成熱損壞。

- 若電池更換不當，可能會有爆炸危險。
- 只能使用製造商建議的相同或同等型號的電池進行更換。
- 請依照製造商的說明處理廢電池。

Electrostatic Discharge (ESD)



CAUTION!

靜電放電 (ESD) 可能會損壞驅動器、電路板和其他零件。我們建議您在 ESD 工作站執行所有操作。如果沒有 ESD 工作站，請在伺服器上處理零件時戴上連接到機殼接地（任何未上漆的金屬表面）的防靜電腕帶，以提供一定的 ESD 保護。

務必小心處理電路板。電路板對靜電放電 (ESD) 極為敏感。僅握住電路板的邊緣，避免接觸任何組件和接腳。從保護包裝或系統中取出電路板後，將電路板組件面朝上放置在接地且無靜電的表面上。如有導電泡棉墊，請使用泡棉墊，但不要使用電路板包裝。請勿將電路板在任何表面上滑動。

系統電源開關：要斷開系統電源，必須將系統從機架中移除。在打開機殼、新增或移除任何非熱插拔組件之前，請確保已將系統從機架中移除。

危險情況、設備和電纜：電源、電話和通訊電纜上可能有危險的電氣狀況。維修系統

前，請關閉系統並斷開連接到系統的電纜。否則，可能導致人身傷害或設備損壞。

靜電放電 (ESD) 和電路板操作：操作電路板時請務必小心。電路板對靜電放電 (ESD) 極為敏感。只能握住電路板的邊緣。從保護包裝或系統中取出電路板後，將電路板的元件面朝上放置在接地且無靜電的表面上。如有導電泡棉墊，請使用泡棉墊，但不要使用電路板包裝。請勿將電路板在任何表面上滑動。

安裝或拆卸跳線：跳線是一種小型塑膠封裝導體，可套在兩個跳線接腳上。有些跳線頂部有一個小卡舌，可以用指尖或細尖嘴鉗夾住。如果跳線沒有這樣的卡舌，使用尖嘴鉗拆卸或安裝跳線時要小心；用鉗子夾住跳線的窄邊，切勿夾住寬邊。夾住寬邊可能會損壞跳線內部的接點，導致此跳線控制的功能出現間歇性故障。使用鉗子或其他工具拆卸跳線時，請小心握持，但不要擠壓，否則電路板上的針腳可能會彎曲或斷裂。



CAUTION!

如果電池更換不當或類型錯誤，可能會有爆炸風險。請僅使用製造商建議的相同或同等類型的電池進行更換。請按照製造商的說明處理廢電池。

Regulatory Notices

WEEE Symbol Statement



The symbol shown below is on the product or on its packaging, which indicates that this product must be disposed of with other waste. Instead, the device should be taken to the waste collection centers for activation of the treatment, collection, recycling and disposal procedure. The separate collection and recycling of your waste equipment at the time of disposal will help to conserve natural resources and ensure that it is recycled in a manner that protects human health and the environment.

For more information about where you can drop off your waste equipment for recycling, please contact your local government office, your household waste disposal service or where you purchased the product for details of environmentally safe recycling.

- When your electrical or electronic equipment is no longer useful to you, "take it back" to your local or regional waste collection administration for recycling.

Restriction of Hazardous Substances (RoHS) Directive Statement

Altos products have not intended to add and safe from hazardous substances (Cd, Pb, Hg, Cr+6, PBDE and PBB). The parts and components have been carefully selected to meet RoHS requirement. More- over, we at Altos are continuing our efforts to develop products that do not use internationally banned toxic chemicals.

California Proposition 65 Warning



WARNING!

This product can expose you to chemicals including Lead, which is known to the State of California to cause cancer, and Bisphenol A (BPA), which is known to the State of California to cause birth defects or other reproductive harm. For more information go to www.P65Warnings.ca.gov.



Battery WARNING!

This product can expose you to chemicals including Lead, which is known to the State of California to cause cancer, and Bisphenol A (BPA), which is known to the State of California to cause birth defects or other reproductive harm. For more information go to

www.P65Warnings.ca.gov.

Electrical appliance specifications and operating temperature:

Rating (AC Input)	100-240Vac, 12A-6A, 50-60Hz 100-240V~, 15A-12A, 60-50Hz
Operating Temperature	10° C to 35° C
Non-operating temperature	-40° C to 60° C
Operating humidity	8%-80% (non-condensing)
Non-operating humidity	20%-95% (non-condensing)

工作站相關警告與注意事項



告

為了避免電擊危險或損壞設備請注意:

不要切斷電源線的接地端子，接地端子是一個很重要的安全防護。將電源線接到有接地功能的插座，此插座需位於使用者容易使用的範圍。電源線的配線要避免被踩到，被絆到或被過度彎折，重壓。



告

本設備關機後內部仍存在電源，須拔掉電源線才能完全切掉設備內部的電源。更換零件前請確定電源已經完全切斷。電源線，電話線，網路線可能帶電，維修前除了移除電源線外也請移除所有連接線，避免電擊傷害或是設備損壞。維修非支援熱插拔的零件時須將工作站從機櫃取下才能維修。



告

避免人員燙傷，觸摸磁碟機或是內部零件前請確保該零件已經冷卻。



告

工作站中有高速風扇，維修時請遠離風扇避免受傷。



告

本設備不能用在有兒童出現的區域。



告

如果更換錯誤電池會產生爆炸，請以相同或同型號電池更換使用。廢電池請回收。



警告:如果更換錯誤電池會產生爆炸，請以相同或同型電池更換

廢電池請回收



意

工作站開機時不要長時間移除蓋子，長時間移除蓋子會造成散熱功能失效造成損壞。



意

靜電會損害電子產品，建議您在符合靜電防護的工作環境操作工作站，如果無法確定環境的靜電防護。請穿上靜電手環並且將手環接到有接地的金屬表面如機櫃或機殼。拿取電路板時僅觸碰板子的邊緣，不要觸碰連接器。板子從防靜電包裝取出後只能放置在無靜電的桌面，零件面朝上。如果可以，請使用防靜電泡棉。避免使用靜電袋。避免電路板與任何表面摩擦產生靜電。

依據中華民國國家標準 CNS 15663 第 5 節「含有標示」之規定，列出安圖斯產品中可能含有之「限用物質含有情況標示」

設備名稱：工作站						
單元	限用物質及其化學符號					
	鉛 (Pb) ()	汞 (Hg) ()	鎘 (Cd) ()	六價 鉻 (Cr ⁺⁶) ()	多溴 聯苯 (PBB) ()	多溴二 苯醚 (PBDE)
金屬機構件	—	○	○	○	○	○
塑料機構件	○	○	○	○	○	○
電路板組件	—	○	○	○	○	○
電源供應器	—	○	○	○	○	○
電源線 / 其他線材	—	○	○	○	○	○
風扇	—	○	○	○	○	○
散熱模組 (金屬部分)	—	○	○	○	○	○
儲存設備	—	○	○	○	○	○
備考 1. "○" 係指該項限用物質之百分比含量未超出百分比含量基準值。						
備考 2. "—" 係指該項限用物質為排除項目。						

報驗義務人：

安圖斯科技股份有限公司

新北市汐止區新台五路一段88號6樓

產品介紹

Altos P330 F6 SE 是一款為媒體專業人士、工程師和創作者打造的高效能工作站，專為需要強大運算能力與無縫工作流程整合的使用者設計。搭載 Intel® Xeon® W 處理器與 Intel® W790 晶片組，支援最高 60 核心，提供卓越的多核心效能、出色的穩定性與廣泛的擴充能力，非常適合媒體製作、CAD/CAE 以及視覺模擬等工作負載。

極致效能，滿足高負載需求：

- 支援最高 **60 核心與 120 執行緒**，為媒體製作、模擬與 AI 訓練等提供卓越運算能力。
- 支援最高 **512GB DDR5 ECC 記憶體**，具備極高速記憶體頻寬與強大 I/O 擴充性，滿足高效能工作站需求。

雙高階 GPU 支援，實現極致圖形效能：

- 搭載 **2000W 80+ GOLD 電源供應器**，支援 **雙張高效能顯示卡**，非常適合用於渲染、模擬與 AI 加速等應用。

企業級可靠性與安全性：

- 支援 **ECC 記憶體與軟體 RAID (0/1/5/10)**，確保系統穩定運作與關鍵數據的可靠保護。
- 搭載 **Intel® vPro®、TPM 2.0、安全開機 (Secure Boot) 以及 Intel® PTT**，提供堅固的硬體級安全防護，適用於專業環境。

次世代 I/O 與連接能力：

- 支援 **DDR5-4800 記憶體、Wi-Fi 6、雙 LAN、兩個 M.2 SSD 插槽**，以及多達 **10 個 USB 連接埠**，其中包含 **USB 3.2 Gen 2x2 (20Gbps)** 高速傳輸埠，實現極速資料傳輸。

產品規格

規格		
處理器	規格	Intel® Xeon® W-3400, W-2400, W-3500 and W-2500 系列處理器 (LGA4677)
	數量	1 個
主機板規格	晶片組	Intel® W790 晶片組
	SATA	8 個 SATA3 (6 Gb/s) 埠
	SATA RAID	支援 RAID 0,1,5,10 (via BIOS) 連接埠 (Windows Only) ¹
	網路介面與通訊	2.5 Gb/s BASE-T LAN 埠 (Intel® I226-LM, 支援 Intel vPro®)
		5 Gb/s BASE-T LAN 埠 (Realtek RTL8126-CG)
音效	7.1 CH HD Audio (Realtek® ALC1220)	
記憶體	記憶體槽	8 個 DIMM 槽(四通道)
	記憶體規格	最高支援 64GB, ECC DDR5 4800 MHz RDIMM ²
	總記憶體容量	最高支援 512GB
擴充槽	PCI-E	• 3 個 PCI-E 5.0 x16 槽 2 個 PCI-E 5.0 x16 槽 (16/0, 8/8)
	M.2	• 1 個 M.2 2280/22110 PCI-E 4.0 x4 槽 (NVMe SSD) • 1 個 M.2 2280 PCI-E 4.0 x4 槽 (NVMe SSD) • 1 個 M.2 2230 PCI-E 槽, E Key (無線網路 & 藍芽)
I/O 埠	前 I/O 埠	• 1 個 USB3.2 Gen2x1 10Gbps Type-C 埠 • 2 個 USB3.2 Gen1 Type-A Ports 埠 • System LED (Power/HDD)
	後 I/O 埠	• 1 個 USB3.2 Gen2x2 20Gbps Type-C 埠 • 2 個 USB3.2 Gen1 Type-A 埠 • 2 個 USB 2.0 埠 • 2 個 RJ45 埠 • 6 個 Audio jacks with SPDIF • 清除 CMOS 按鈕 • BIOS flashback 按鈕
安全與管理功能		<ul style="list-style-type: none"> Intel® PTT RAID support (via BIOS) Intel® vPro™ Technology 磁碟密碼保護(via BIOS) Kensington 鎖孔 WOL (Wake on Lan) 內建 TPM v2.0
儲存槽	外露式 (選購)	• 1 個外露式擴充槽：可接光碟機
	內接式	• 4 個 3.5"或 2.5"內接式磁碟機槽：可裝硬碟
電源供應器		<ul style="list-style-type: none"> 850W Multiple output 24 pins, IEC C14 AC 插座, ATX3.1 80PLUS® 金牌級電源供應器 2000W Multiple output 24 pins, IEC C20 AC 插座, 80PLUS® 白金級電源供應器
尺寸 (長 x 寬 x 高)		• 56L, 470 (長) x 230 (寬) x 518.5 (高) mm (18.5 x 9.6 x 20.3 吋)
作業系統		<ul style="list-style-type: none"> Microsoft® Windows 11 Pro 64-bit Red Hat Enterprise Linux 9
系統認證		BSMI, CE, FCC, CB, MET, ENERGY STAR 8.0

產品外觀

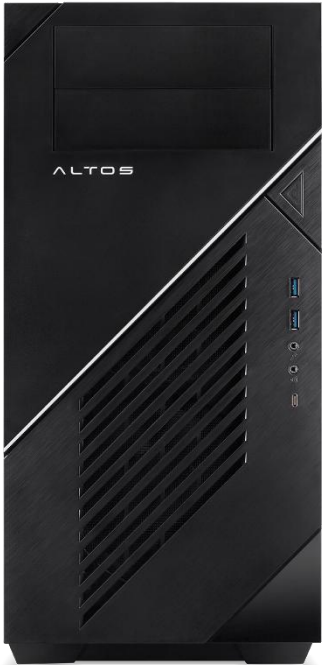

前方示意圖



1 5.25-inch External accessible bay

2 Power Button/Power LED/HDD LED

3 2 USB3.2 Gen1 Type-A Ports

4 HDD Activity LED

5 HD Audio

主機板介紹

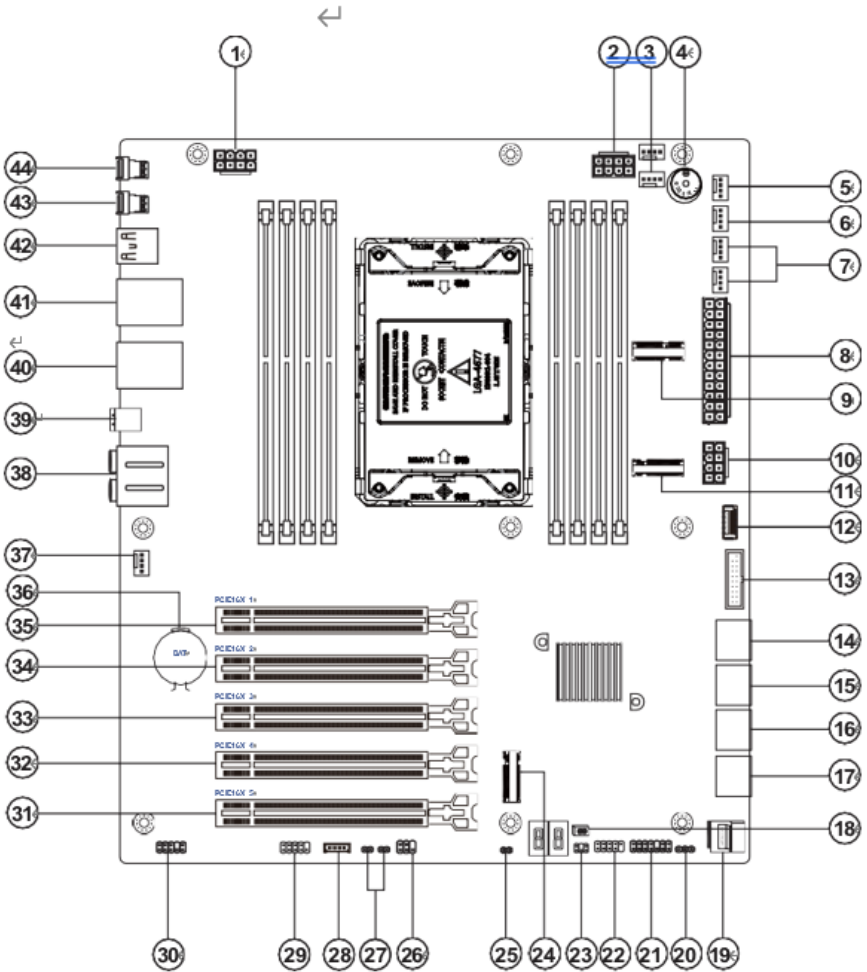

Item	Code	Description
1	ATX_12V2	8-pin +12V power connector
2	ATX_12V1	8-pin +12V power connector
3	CPU_FAN	4-pin CPU cooling fan header
4	BZ	Buzzer header
5	PUMP_FAN	XXXXXXXXXXXXXXXXXXXX
6	SYS_FAN1	4-pin System cooling fan header #1

7	AUX_FAN1~2	XXXXXXXXXXXXXXXXXXXX
8	ATX_POWER	Standard 24-pin ATX power connector
9	M.2_1	M.2 2230 Key E slot for WiFi/CNVi
10	PCIE_8PIN_PWR	8-pin +12V power connector
11	M2_2	M.2 2280/22110 Key M slot for SSD Gen5 x4
12	F_U32G2X2	20-pin USB 3.2 Gen2 x2 header (Type C)
13	F_USB3G1	20-pin USB 3.2 Gen1 headers (Type A)
14	SATA3_D7U8	Serial ATA 6Gb/s connectors #7~8
15	SATA3_D5U6	Serial ATA 6Gb/s connectors #5~6
16	SATA3_D3U4	Serial ATA 6Gb/s connectors #3~4
17	SATA3_D1U2	Serial ATA 6Gb/s connectors #1~2
18	C_INTRUSION	2-pin Intrusion Alarm Pin header
19	SLIMSAS1	XXXXXXXXXXXXXXXXXXXX
20	12C_UPDATE	XXXXXXXXXXXXXXXXXXXX
21	F_PANEL	Front panel switch/LED header
22	FUSB2	Front panel USB 2.0 headers
23	THER_HD1	XXXXXXXXXXXXXXXXXXXX
24	M2_3	M.2 2260/2280 Key M slot for SSD PCIE Gen4 x4
25	FW_DEBUG	XXXXXXXXXXXXXXXXXXXX
26	ELOCK	XXXXXXXXXXXXXXXXXXXX
27	A1~2	XXXXXXXXXXXXXXXXXXXX
28	VROC_KEY	XXXXXXXXXXXXXXXXXXXX
29	BMC_HEADER	XXXXXXXXXXXXXXXXXXXX
30	F_AUDIO	Front panel audio header
31	PCIE16X_5	PCIe x16 Slot (Gen5 x16)
32	PCIE16X_4	PCIe x16 Slot (Gen5 x16)
33	PCIE16X_3	PCIe x16 Slot (Gen5 x16)
34	PCIE16X_2	PCIe x16 Slot (Gen5 x16)
37	PCIE16X_1	PCIe x16 Slot (Gen5 x16)
36	BT	Battery Socket
37	SYS_FAN2	4-pin system cooling fan header
38	AUDIO	Audio Connectors
39	RU32G2X2C	1*USB 3.2 Gen2x2 port Type-C
40	USB3LAN2G5	1*Intel I226-LM 2.5G LAN + 2*USB 3.2 Gen1 ports Type-A
41	USB3LAN5G	1*RTL8126-CG 5G LAN + 2*USB 3.2 Gen2x1 ports Type-A
42	R_USB2_1	Front panel USB 2.0 headers
43	CLR_CMOS_BTN	CLR_CMOS Button
44	BIOS_FLBK_BTN	BIOS Flashback Button

方塊圖

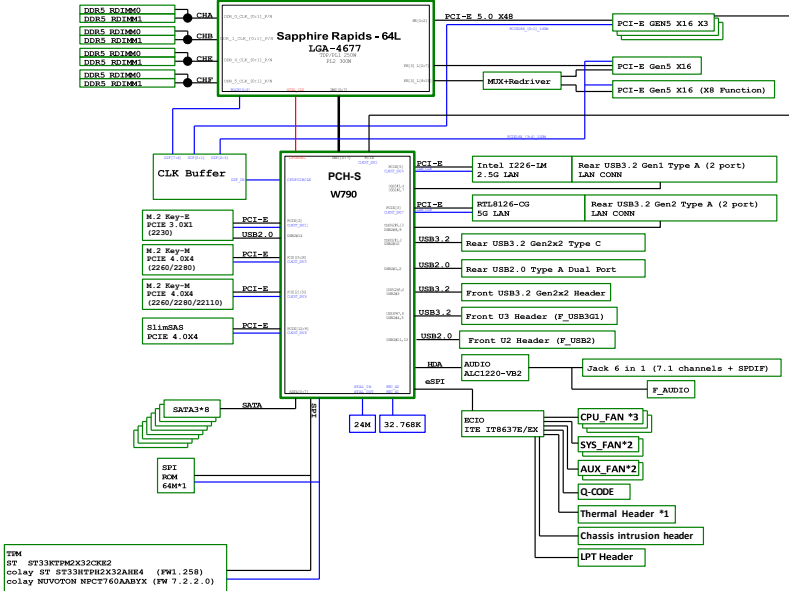

Chapter 1 Hardware Installation

Installing and Removing the CPU



Read the following guidelines before you begin to install the CPU:

- Make sure that the motherboard supports the CPU.
- Always turn off the computer and unplug the power cord from the power outlet before installing the CPU to prevent hardware damage.
- Unplug all cables from the power outlets.
- Disconnect all telecommunication cables from their ports.
- Place the system unit on a flat and stable surface.
- Open the system according to the instructions.

WARNING!

Failure to properly turn off the server before you start installing components may cause serious damage. Do not attempt the procedures described in the following sections unless you are a qualified service technician.

Follow these instructions to Install the CPU:

1. Align and install the processor on the carrier.

NOTE: Apply thermal compound evenly on the top of the CPU. Remove the protective cover from the underside of the heat sink.

2. Carefully flip the heat sink cover. Then install the carrier assembly on the bottom of the heat sink and make sure the gold arrow is located in the correct direction.

3. Remove the CPU cover.

NOTE: Save the CPU cover in the event that you need to remove the CPU from the socket.

4. Align the heat sink with the CPU socket by the guide pins and make sure the gold arrow is located in the correct direction. Then place the heat sink onto the top of the CPU socket.

5. Position the rotating wires into the latch position. Tighten the screws in a sequential order (1→2→3→4).

NOTE: When disassembling the heat sink, loosen the screws in reverse order (4→3→2→1) and then move the rotating wires into the unlatch position.

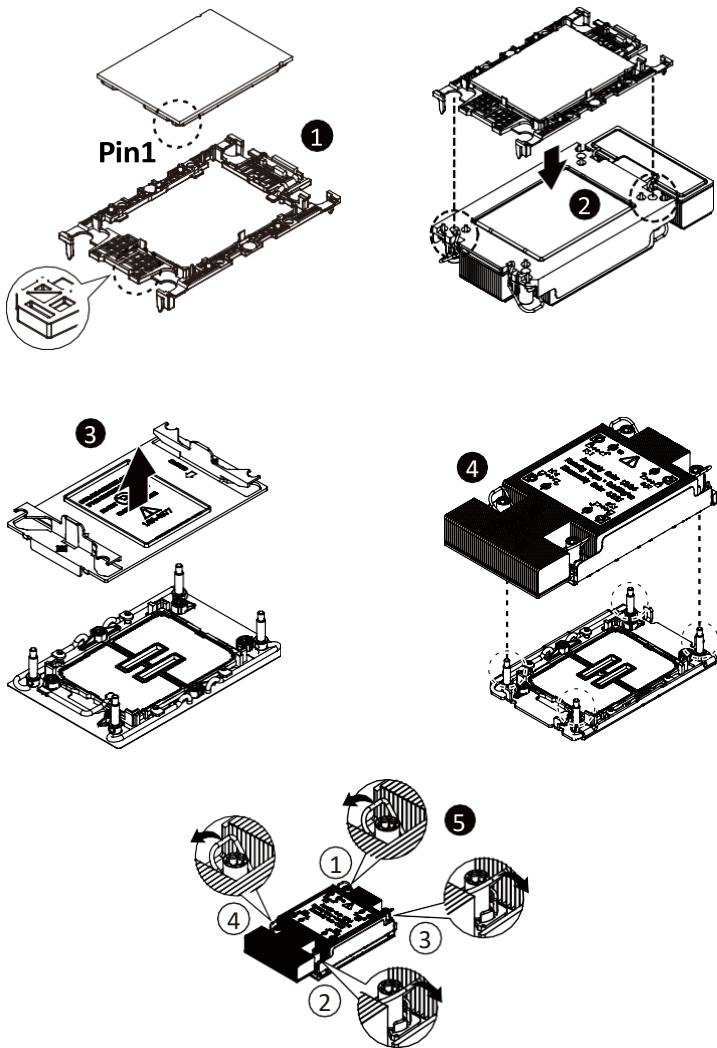

Note!

- The illustrations of the heat-sink installation shown are for reference only..

1-1 Installing and Removing Memory



Read the following guidelines before you begin to install the memory:

- Make sure that the motherboard supports the memory. It is recommended to use memory of the same capacity, brand, speed, and chips.
- Always turn off the computer and unplug the power cord from the power outlet before installing the memory to prevent hardware damage.
- Memory modules have a foolproof design. A memory module can be installed in only one direction. If you are unable to insert the memory, switch the direction.

1-1-1 4-Channel Memory Configuration

This motherboard provides 8 DDR5 memory slots and supports 4-Channel Technology. After the memory is installed, the BIOS will automatically detect the specifications and capacity of the memory.

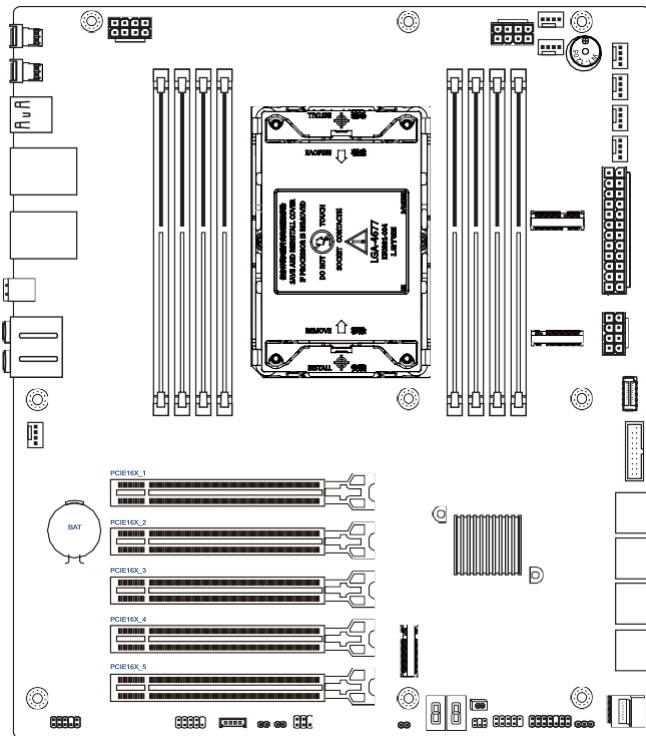

1-1-2 Installing and Removing a Memory Module



Before installing a memory module, make sure to turn off the computer and unplug the power cord from the power outlet to prevent damage to the memory module.

Be sure to install DDR5 DIMMs on this motherboard.

Follow these instructions to install a DIMM module:

1. Insert the DIMM memory module vertically into the DIMM slot and push it down.
2. Close the plastic clip at both edges of the DIMM slots to lock the DIMM module.
3. Reverse the installation steps when you want to remove the DIMM module.

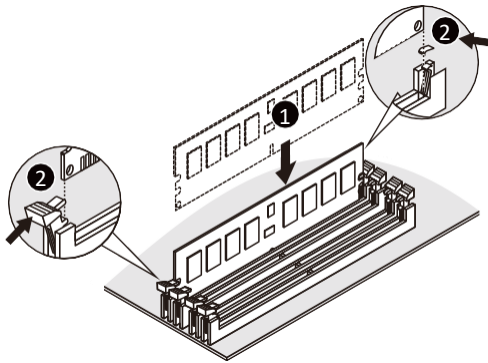

1-1-3 DIMM Population Table

Type	Ranks Per DIMM and Data Width	DIMM Capacity (GB)	Speed (MT/s); Voltage (V); DIMM per Channel (DPC)	
			1DPC*	2DPC*
		16Gb	1.1V	
RDIMM	SRx8 (RC D)	16GB	4800	4400
	SRx4 (RC C)	32GB		
	DRx8 (RC E)	32GB		
	DRx4 (RC A)	64GB		
RDIMM 3DS	(4R/8R)x4 (RC A)	2H-128GB 4H-256GB		

*1DPC applies to 1SPC or 2SPC implementations (SPC - Sockets Per Channel)

1-2 Installing the M.2 SSD Module

Follow the steps below to install a M.2 SSD module on your motherboard.

Step1. Insert the M.2 SSD module into the slot.

Step2. Secure it with the screw, tightening as necessary to fasten the M.2 SSD module in place.

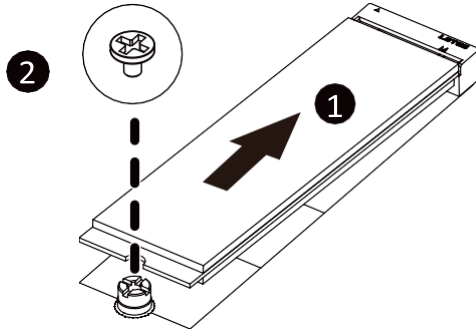

1-3 Back Panel Connectors

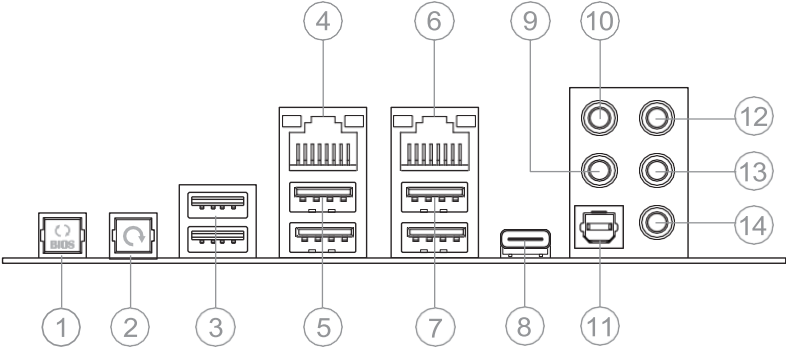

1. BIOS_FLBK_BTN
XXXXXXXXXXXXXXXXXXXXXXXXXXXXX.

2. CLR_CMOS_BTN
XXXXXXXXXXXXXXXXXXXXXXXXXXXXX.

3. RUSB 2_1 Ports
Use the USB 2.0 ports to connect USB 2.0 devices.

4. 5GbE LAN Port
The Gigabit Ethernet LAN port provides Internet connection at up to 5 Gbps data rate. See the section below for a description of the states of the LAN port LEDs.

5. USB 3.2 Gen2x1 Type A ports
The USB port supports the USB 3.2 specification. Use this port for USB devices such as a USB keyboard/mouse, USB printer, USB flash drive etc.

6. 2.5GbE LAN Port
The Gigabit Ethernet LAN port provides Internet connection at up to 2.5 Gbps data rate. See the section below for a description of the states of the LAN port LEDs.

7. USB 3.2 Gen1 Type A ports
The USB port supports the USB 3.2 specification. Use this port for USB devices such as a USB keyboard/mouse, USB printer, USB flash drive etc.

8. USB 3.2 Gen2x2 Type C port
The USB port supports the USB 3.2 specification. Use this port for USB devices such as a USB keyboard/mouse, USB printer, USB flash drive etc.

9. Center/Sub out
XXXXXXXXXXXXXXXXXXXXXXXXXXXXX.

10. Side Surround L/R

XXXXXXXXXXXXXXXXXXXXXXXXXXXXX.

11. Rear Surround L/R

XXXXXXXXXXXXXXXXXXXXXXXXXXXXX.

12. Line-in (blue)

The default Line in jack. Use this audio jack for line in devices such as an optical drive, walkman, etc

13. Line-out (Green)

The default Line Out jack. Use this audio jack for a headphone or 2-channel speaker. This jack can be used to connect front speakers in a 4/5.1/7.1-channel audio configuration.

14. Mic In (Pink)

The default MIC In jack. A microphone can be connected to the MIC In jack.

2.5GbE LAN LED:

Status	Description
Yellow On	1 Gbps, 100Mbps data rate
Green On	2.5 Gbps data rate
Off	10 Mbps data rate

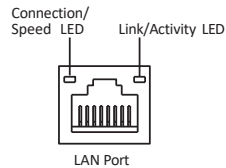

0/100/1000 LAN LED:

Status	Description
Yellow On	1 Gbps data rate
Green On	100 Mbps data rate
Off	10 Mbps data rate

ID Button / LED:

Status	Description
Blue on	System identification is active
Off	System identification is disable



- When removing the cable connected to a back panel connector, first remove the cable from your device and then remove it from the motherboard.
- When removing the cable, pull it straight out from the connector. Do not rock it side to side to prevent an electrical short inside the cable connector.

1-4 Internal Connectors

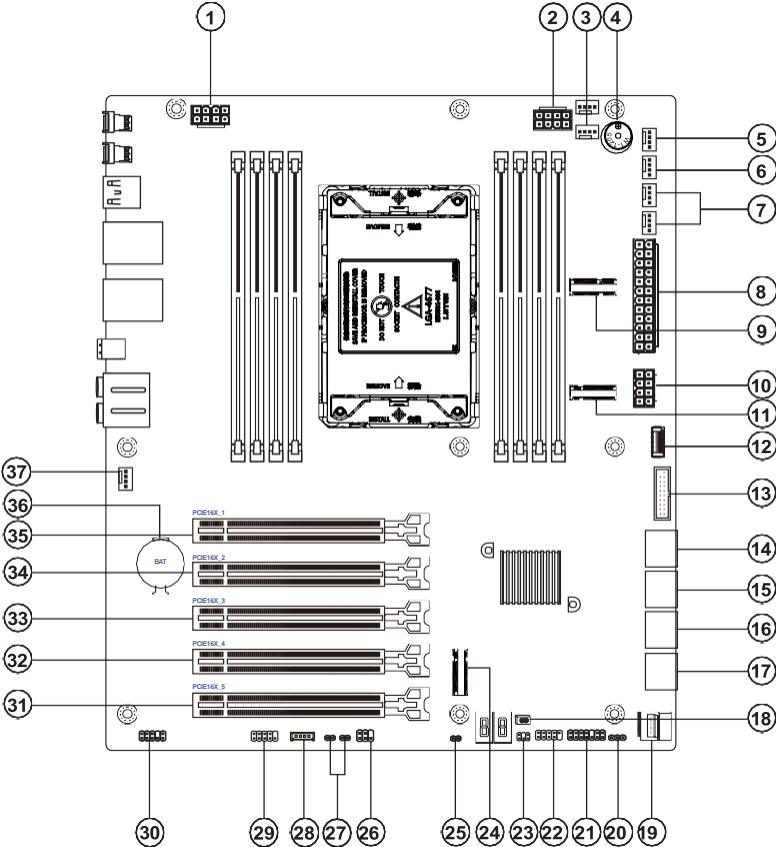

No.	Code	Description	No.	Code	Description
1	ATX_12V2	8-pin +12V power connector	20	I2C_UPDATE	
2	ATX_12V1	8-pin +12V power connector	21	F_PANEL	Front panel switch/LED header
3	CPU_FAN	4-pin CPU cooling fan header	22	FUSB2	Front panel USB 2.0 headers
4	BZ	Buzzer header	23	THER_HD1	System Thermal Sensor Header
5	PUMP_FAN	XXXXXXXX	24	M2_3	M.2 2260/2280 Key M slot for SSD PCIe Gen4 x4
6	SYS_FAN1	4-pin System cooling fan header #1	25	FW_DEBUG	XXXXXXXX
7	AUX_FAN1~2	XXXXXXXX	26	ELOCK	XXXXXXXX
8	ATX_POWER	Standard 24-pin ATX power connector	27	A1~2	XXXXXXXX
9	M.2_1	M.2 2230 Key E slot for WiFi/CNVi	28	VROC_KEY	XXXXXXXX
10	PCI_E8PIN_PWR	8-pin +12V power connector	29	BMC_HEADER	XXXXXXXX
11	M2_2	M.2 2280/22110 Key M slot for SSD Gen5 x4	30	F_AUDIO	Front panel audio header
12	F_U32G2X2	20-pin USB 3.2 Gen2 x2 header (Type C)	31	PCI_E16X_5	PCIe x16 Slot (Gen5 x16)
13	F_USB3G1	20-pin USB 3.2 Gen1 headers (Type A)	32	PCI_E16X_4	PCIe x16 Slot (Gen5 x16)
14	SATA3_D7U8	Serial ATA 6Gb/s connectors #7~8	33	PCI_E16X_3	PCIe x16 Slot (Gen5 x16)
15	SATA3_D5U6	Serial ATA 6Gb/s connectors #5~6	34	PCI_E16X_2	PCIe x16 Slot (Gen5 x16)
16	SATA3_D3U4	Serial ATA 6Gb/s connectors #3~4	35	PCI_E16X_1	PCIe x16 Slot (Gen5 x16)
17	SATA3_D1U2	Serial ATA 6Gb/s connectors #1~2	36	BT	Battery Socket
18	C_INTRUSION	2-pin Intrusion Alarm Pin header	37	SYS_FAN2	4-pin system cooling fan header
19	SLIMSAS1	XXXXXXXX			



Read the following guidelines before connecting external devices:

- First make sure your devices are compliant with the connectors you wish to connect.
- Before installing the devices, be sure to turn off the devices and your computer. Unplug the power cord from the power outlet to prevent damage to the devices.
- After installing the device and before turning on the computer, make sure the device cable has been securely attached to the connector on the motherboard.

1/2/8/10) ATX_12V1/ATX_12V2/PCIE_8PIN_PWR (2x4 12V Power Connector and 2x12 Main Power Connector)

With the use of the power connector, the power supply can supply enough stable power to all the components on the motherboard. Before connecting the power connector, first make sure the power supply is turned off and all devices are properly installed. The power connector possesses a foolproof design. Connect the power supply cable to the power connector in the correct orientation. The 12V power connector mainly supplies power to the CPU. If the 12V power connector is not connected, the computer will not start.

To meet expansion requirements, it is recommended that a power supply that can withstand high power consumption be used (500W or greater). If a power supply is used that does not provide the required power, the result can lead to an unstable or unbootable system.



To meet expansion requirements, it is recommended that a power supply that can withstand high power consumption be used (500W or greater). If a power supply is used that does not provide the required power, the result can lead to an unstable or unbootable system.

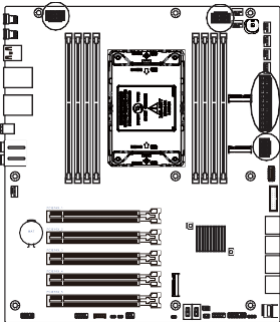

ATX_12V1/ATX_12V2/PCIE_8PIN_PWR

Pin No.	Definition	Pin No.	Definition
1	GND	5	+12V
2	GND	6	+12V
3	GND	7	+12V
4	GND	8	+12V



ATX_POWER

Pin No.	Definition	Pin No.	Definition
1	3.3V	13	3.3V
2	3.3V	14	-12V
3	GND	15	GND
4	+5V	16	PS_ON
5	GND	17	GND
6	+5V	18	GND
7	GND	19	GND
8	Power Good	20	NC
9	5VSB	21	+5V
10	+12V	22	+5V
11	+12V	23	+5V
12	3.3V	24	GND

3/5/6/7/37) CPU_FAN/PUMP_FAN/SYS_FAN1/AUX_FAN1~2/SYS_FAN2 (CPU Fan/PUMP_FAN/System Fan/AUX_FAN Headers)

The motherboard has two 4-pin CPU fan headers (CPU_FAN), one 4-pin PUMP fan header (PUMP_FAN), two 4-pin system fan headers (SYS_FAN) and two 4-pin AUX fan headers (AUX_FAN1~2). Most fan headers possess a foolproof insertion design. When connecting a fan cable, be sure to connect it in the correct orientation (the black connector wire is the ground wire). The motherboard supports CPU fan speed control, which requires the use of a CPU fan with fan speed control design. For optimum heat dissipation, it is recommended that a system fan be installed inside the chassis.

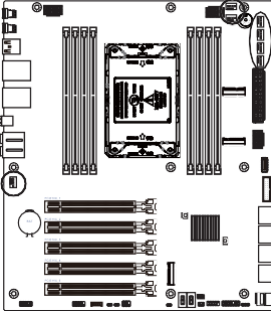

Pin No.	Definition	Pin No.	Definition
1	GND	3	Sense
2	+12V	4	Speed Control

4) BZ: Buzzer Header

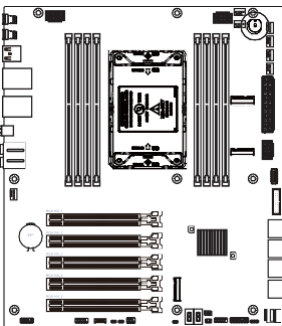

Pin No.	Definition	Pin No.	Definition
1	Power +5V	3	GND
2	_	4	Signal

12) F_U32G2X2 (Front Panel USB 3.2 Gen2 x2 Header)

This Motherboard implements one USB 3.2 Gen2 x2 header (Type C) supporting 2 extra front USB 3.2 Gen2 x2 ports, which delivers 10Gb/s transfer rate.

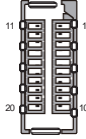
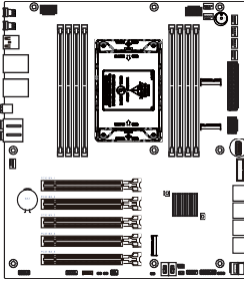

Pin No.	CC2	Pin No.	Definition
1	VBUS	11	CC2
2	TX1+	12	D+
3	TX1-	13	D-
4	GND	14	GND
5	RX1+	15	RX2-
6	RX1-	16	RX2+
7	VBUS	17	GND
8	CC1	18	TX2-
9	-	19	TX2+
10	-	20	VBUS

13) F_USB3G1 (Front Panel USB 3.2 Gen1 Connector)

The connectors conform to USB 3.2 specification. Each USB header can provide two USB ports via an optional USB bracket. For purchasing the optional USB bracket, please contact the local dealer.

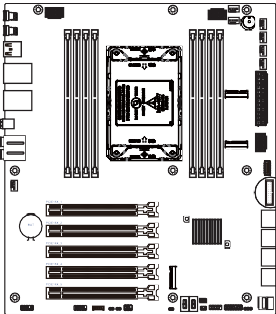

Pin No.	CC2	Pin No.	Definition
1	Power	11	IntA_P2_D+
2	IntA_P1_SSRX-	12	IntA_P2_D-
3	IntA_P1_SSRX+	13	GND
4	GND	14	IntA_P2_SSTX+
5	IntA_P1_SSTX-	15	IntA_P2_SSTX-
6	IntA_P1_SSTX+	16	GND
7	GND	17	IntA_P2_SSRX+
8	IntA_P1_D-	18	IntA_P2_SSRX-
9	IntA_P1_D+	19	Power
10	NC	20	-

14/15/16/17) SATA3_D7U8/SATA3_D5U6/SATA3_D3U4/SATA3_D1U2 (Serial ATA Connectors)

SATA 1~8 connectors support the Serial ATA 6Gb/s device, simpler disk drive cabling and easier PC assembly. It eliminates limitations of the current Parallel ATA interface. But maintains register compatibility and software compatibility with Parallel ATA.

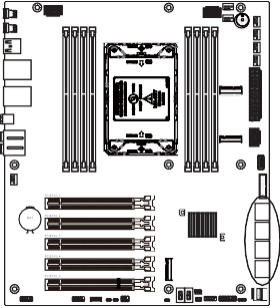

Pin No.	Definition	Pin No.	Definition
1	Ground	5	TX-
2	RX-	6	TX+
3	RX+	7	Ground
4	Ground	8	-

18) C_INTRUSION (Case Open Intrusion Alert Header)

This motherboard provides a chassis detection feature that detects if the chassis cover has been removed. This function requires a chassis with chassis intrusion detection design.

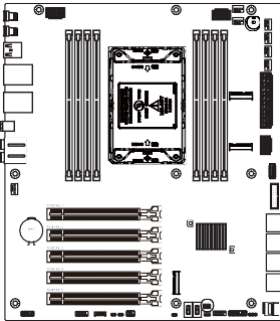

Open: Normal Operation (Default)



Closed: Active Chassis Intrusion Alert

19) SLIMSAS1 (XXXXXXXXXXXXXXXXXXXXXX)

XXXXXXXXXXXXXXXXXXXXXX.

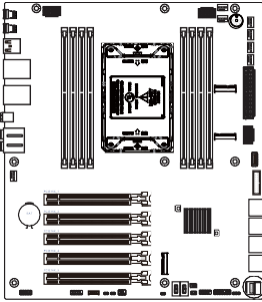

Pin No.	Definition	Pin No.	Definition
1			
2			
3			
4			

20) 12C_UPDATE (XXXXXXXXXXXXXXXXXXXXXX)

XXXXXXXXXXXXXXXXXXXXXX.

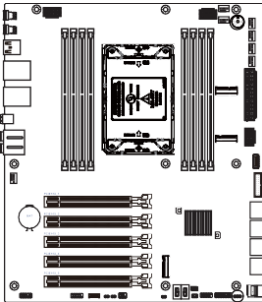

Pin No.	Definition
1	Ground
2	RX-
3	RX+

21) F_PANEL (Front panel header)

The front panel header (F_PANEL) provides a standard set of switch and LED headers commonly found on ATX or Micro ATX cases.

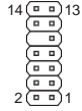
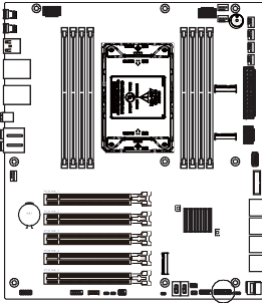

Pin No.	CC2	Pin No.	Definition
1	HDD LED Power	8	GND
2	GLED0	9	NC
3	HDD_LED	10	KEY
4	GLED1	11	+5VSB
5	GND	12	LAN_LED
6	PWRSW	13	NC
7	HWRST_L	14	LAN_LED

22) USB2 (Front Panel USB 2.0 Header)

The onboard F_USB1 header delegates for card reader, it supports additional one USB 2.0 port.

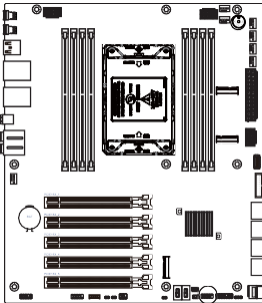

Pin No.	CC2	Pin No.	Definition
1	Power +5V	6	USB Port B (+)
2	Power +5V	7	GND
3	USB Port A (-)	8	GND
4	USB Port B (-)	9	-
5	USB Port A (+)	10	NC

23) THER_HD1 (System Thermal Sensor Header)

XXXXXXXXXXXXXXXXXXXXX XX
 XXXXXX.

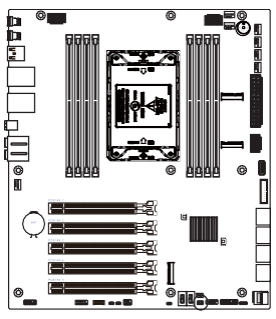

Pin No.	CC2	Pin No.	Definition
1	XXXXXXXXXX	4	-
2	XXXXXXXXXX	5	XXXXXXXXXX
3	XXXXXXXXXX	6	XXXXXXXXXX

25) FW_DEBUG (Front Panel USB 2.0 Header)

XXXXXXXXXXXXXXXXXXXXX XX
 XXXXXX.

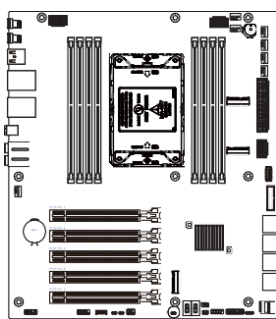

Pin No.	CC2
1	XXXXXXXXXX
2	XXXXXXXXXX

26) ELOCK (XXXXXXXXXXXXXXXXXX)

XX
 XXXXXX.

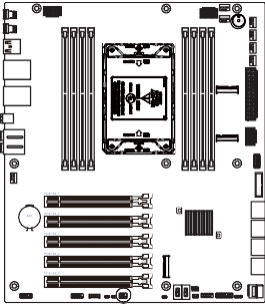

Pin No.	CC2	Pin No.	Definition
1	XXXXXXXX	4	-
2	XXXXXXXX	5	XXXXXXXX
3	XXXXXXXX	6	XXXXXXXX

27) A1~2 (2-pin GPIO Headers)

XX
 XXXXXX.

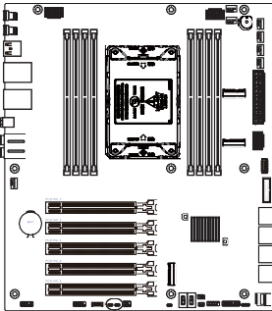

Pin No.	CC2
1	GPIO
2	GND

28) VROC_KEY (XXXXXXXXXXXXXXXXXX)

XX
 XXXXXX.

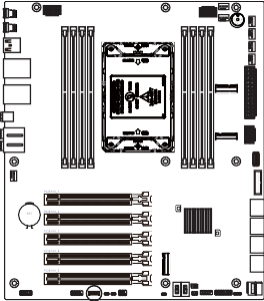

Pin No.	CC2	Pin No.	Definition
1	XXXXXXXXXX	3	XXXXXXXXXX
2	XXXXXXXXXX	4	XXXXXXXXXX

29) BMC_HEADER (XXXXXXXXXXXXXXXXXX)

XX
 XXXXXX.

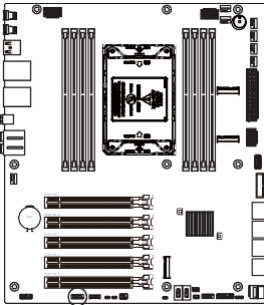

Pin No.	CC2	Pin No.	Definition
1	XXXXXXXXXX	6	XXXXXXXXXX
2	XXXXXXXXXX	7	XXXXXXXXXX
3	XXXXXXXXXX	8	XXXXXXXXXX
4	XXXXXXXXXX	9	XXXXXXXXXX
5	XXXXXXXXXX	10	-

30) F_AUDIO (Front Panel Audio Header)

The front panel audio header supports High Definition audio (HD). You may connect your chassis front panel audio module to this header. Make sure the wire assignments of the module connector match the pin assignments of the motherboard header. Incorrect connection between the module connector and the motherboard header will make the device unable to work or even damage it.

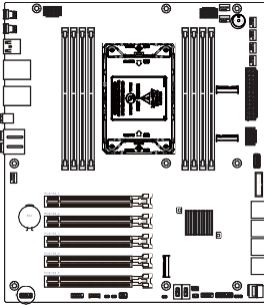

Pin No.	CC2	Pin No.	Definition
1	MIC-L	6	GND
2	GND	7	AUDIO_JD
3	MIC-R	8	-
4	Power(3.3V)	9	LINE-L
5	LINE-R	10	GND



Some chassis provide a front panel audio module that has separated connectors on each wire instead of a single plug. For information about connecting the front panel audio module that has different wire assignments, please contact the chassis manufacturer

36) BT (Battery Socket)

The battery provides power to keep the values (such as BIOS configurations, date, and time information) in the CMOS when the computer is turned off. Replace the battery when the battery voltage drops to a low level, or the CMOS values may not be accurate or may be lost.

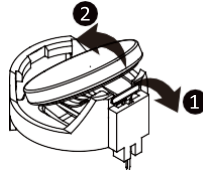
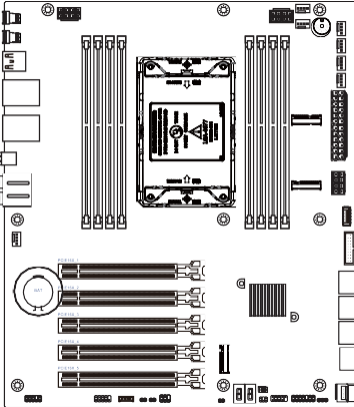

- Always turn off your computer and unplug the power cord before replacing the battery.
- Replace the battery with an equivalent one. Danger of explosion if the battery is replaced with an incorrect model.
- Contact the place of purchase or local dealer if you are not able to replace the battery by yourself or uncertain about the battery model.
- Used batteries must be handled in accordance with local environmental regulations.

1-5 Jumper Settings

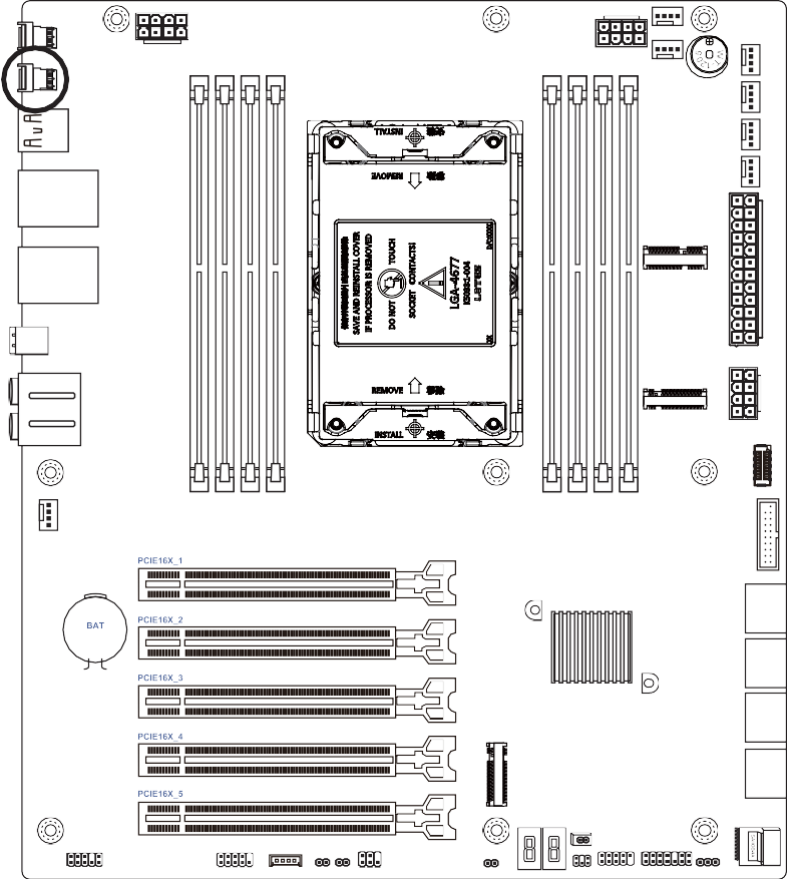

Jumper Name	Jumper Setting
Clear CMOS	1-2: Normal operation (Default) 2-3: Clear CMOS data

Chapter 2 BIOS Setup

BIOS (Basic Input and Output System) records hardware parameters of the system in the EFI on the motherboard. Its major functions include conducting the Power-On Self-Test (POST) during system startup, saving system parameters, loading the operating system etc. The BIOS includes a BIOS Setup program that allows the user to modify basic system configuration settings or to activate certain system features. When the power is turned off, the battery on the motherboard supplies the necessary power to the CMOS to keep the configuration values in the CMOS.

To access the BIOS Setup program, press the key during the POST when the power is turned on.



- BIOS flashing is potentially risky, if you do not encounter any problems when using the current BIOS version, it is recommended that you don't flash the BIOS. To flash the BIOS, do it with caution. Inadequate BIOS flashing may result in system malfunction.
- It is recommended that you not alter the default settings (unless you need to) to prevent system instability or other unexpected results. Inadequately altering the settings may result in system's failure to boot. If this occurs, try to clear the CMOS values and reset the board to default values. (Refer to the Exit section in this chapter or introductions of the battery/clearing CMOS jumper in Chapter 1 for how to clear the CMOS values.)

BIOS Setup Program Function Keys

<f><g>	Move the selection bar to select the screen
<h><i>	Move the selection bar to select an item
<+>	Increase the numeric value or make changes
<->	Decrease the numeric value or make changes
<Enter>	Execute command or enter the submenu
<Esc>	Main Menu: Exit the BIOS Setup program Submenus: Exit current submenu
<F1>	Show descriptions of general help
<F3>	Restore the previous BIOS settings for the current submenu
<F9>	Load the Optimized BIOS default settings for the current submenu
<F10>	Save all the changes and exit the BIOS Setup program

■ Main

This setup page includes all the items of the standard compatible BIOS.

■ Advanced

This setup page includes all the items of AMI BIOS special enhanced features.
(ex: Auto detect fan and temperature status, automatically configure hard disk parameters.)

■ Chipset

This setup page includes all the submenu options for configuring the functions of the Platform Controller Hub.

■ Server Management

Server additional features enabled/disabled setup menus.

■ Security

Change, set, or disable supervisor and user password. Configuration supervisor password allows you to restrict access to the system and BIOS Setup.

A supervisor password allows you to make changes in BIOS Setup.

A user password only allows you to view the BIOS settings but not to make changes.

■ Boot

This setup page provides items for configuration of the boot sequence.

■ Save & Exit

Save all the changes made in the BIOS Setup program to the CMOS and exit BIOS Setup. (Pressing <F10> can also carry out this task.)

Abandon all changes and the previous settings remain in effect. Pressing <Y> to the confirmation message will exit BIOS Setup. (Pressing <Esc> can also carry out this task.)

2-1 The Main Menu

Once you enter the BIOS Setup program, the Main Menu (as shown below) appears on the screen. Use arrow keys to move among the items and press <Enter> to accept or enter other sub-menu.

Main Menu Help

The on-screen description of a highlighted setup option is displayed on the bottom line of the Main Menu.

Submenu Help

While in a submenu, press <F1> to display a help screen (General Help) of function keys available for the menu. Press <Esc> to exit the help screen. Help for each item is in the Item Help block on the right side of the submenu.



- When the system is not stable as usual, select the Restore Defaults item to set your system to its defaults.
- The BIOS Setup menus described in this chapter are for reference only and may differ by BIOS version.

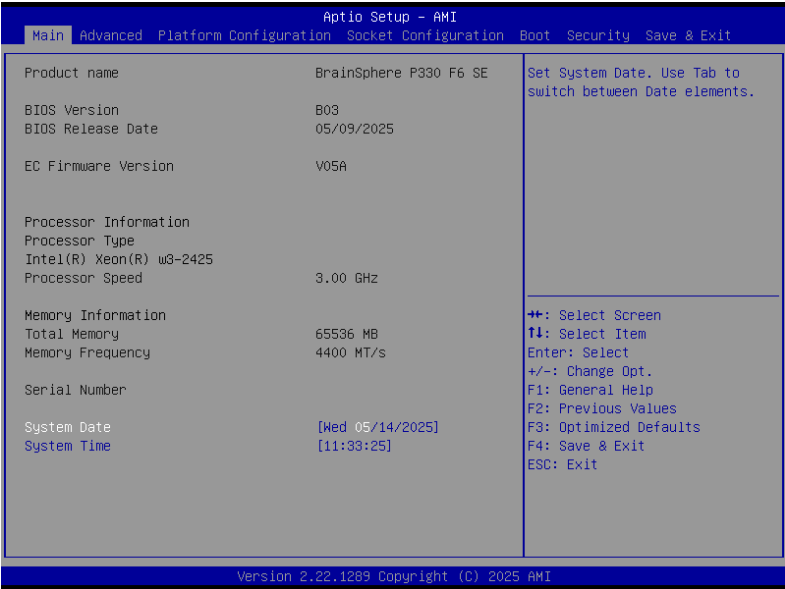

Parameter	Description
Project Name	Displays the project name information.
BIOS Version	Displays the information of system BIOS version.
BIOS Release Date	Displays the BIOS Release Date of system BIOS.
EC Firmware Version	Displays the information of EC firmware version.
Processor Information	Displays the technical information for the installed processor(s).
Processor Type	XXXXXXXXXXXXXX
Intel(R) Xeon(R) w3-2425	XXXXXXXXXXXXXX
Processor Speed	This item shows the processor speed.
Memory Information	Displays the information of the memory size.
Total Memory	Displays the total memory size of the installed memory.
Memory Frequency	Displays the frequency information of the installed memory.
Serial Number	This item shows the information of system serial number.
System Date	Sets the date following the weekday-month-day-year format.
System Time	Sets the system time following the hour-minute-second format.

2-2 Advanced Menu

The Advanced Menu displays submenu options for configuring the function of various hardware components. Select a submenu item, then press <Enter> to access the related submenu screen.

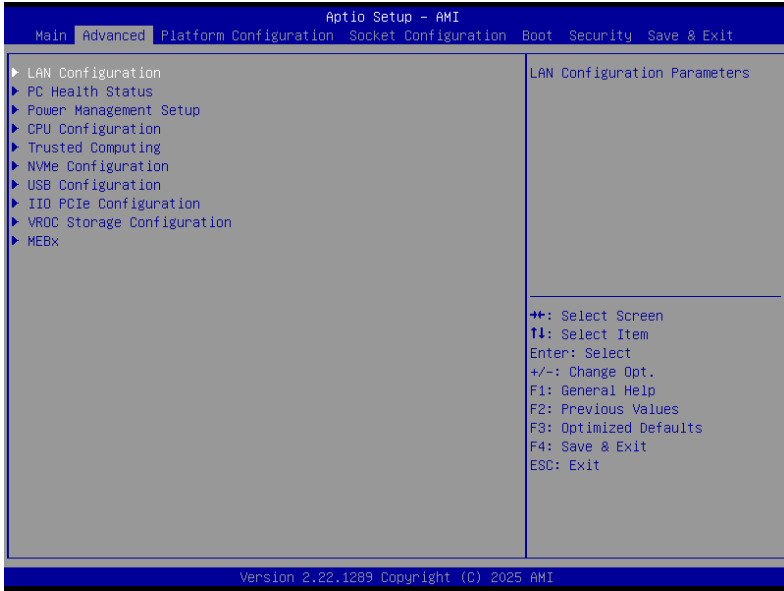

2-2-1 LAN Configuration

The item in the menu shows the LAN-related information that the BIOS automatically detects.

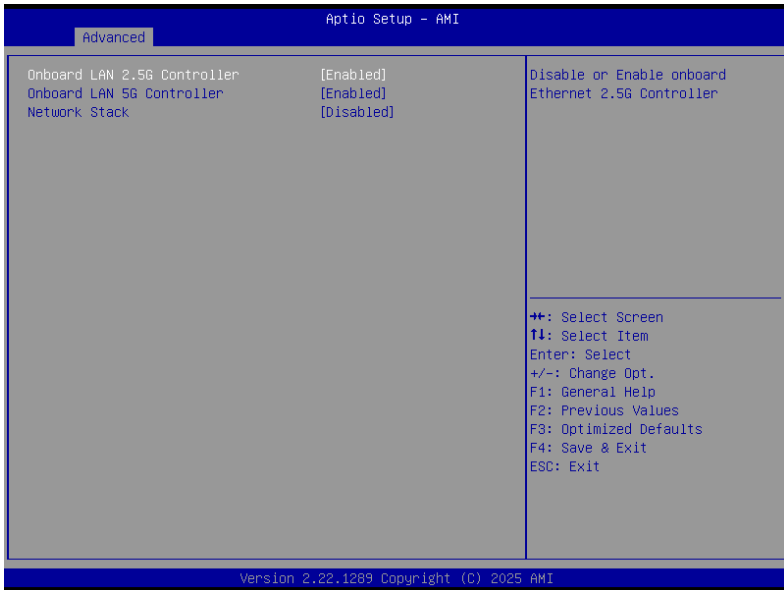

Parameter	Description
Onboard LAN 2.5G Controller	Use this item to enable or disable Onboard Intel I226-LM 2.5G LAN controller.
Onboard LAN 5G Controller	Use this item to enable or disable Onboard RTL8126-CG 5G LAN controller.
Network stack	Use this item to enable or disable Network Boot

2-2-2 PC Health Status

On motherboards support hardware monitoring, this item lets you monitor the parameters for critical voltages, temperatures and fan speeds.

The screenshot shows the BIOS interface with the 'Advanced' tab selected. The 'Pc Health Status' menu is open, displaying various system parameters. On the right side, there is a legend for navigation keys. The bottom of the screen shows the version and copyright information.

Pc Health Status		Display SIO Smart Fan Function
▶ Smart Fan Function		
CPU Temperature	: + 54 °C	
PCH Temperature	: + 60 °C	
System Temperature	: + 40 °C	
VRD Temperature	: + 54 °C	
Case Temperature	: N/A	
CPU Fan 1 Speed	: 1762 RPM	
CPU Fan 2 Speed	: N/A	
SYS Fan 1 Speed	: N/A	
SYS Fan 2 Speed	: N/A	
Aux Fan 1 Speed	: N/A	
Aux Fan 2 Speed	: N/A	
Pump Fan Speed	: N/A	
Core Voltage	: + 0.873 V	
VCCIN 1.6V	: + 1.815 V	
VDIMM	: + 1.144 V	
+12V	: +11.814 V	
+5V	: + 5.032 V	
+3P3V	: + 3.319 V	
+5V Dual	: + 5.033 V	

←→: Select Screen
F1: Select Item
Enter: Select
+/-: Change Opt.
F1: General Help
F2: Previous Values
F3: Optimized Defaults
F4: Save & Exit
ESC: Exit

Version 2.22.1289 Copyright (C) 2025 AMI

► **2-2-2-1 Smart Fan Function**

Scroll to this item and press <Enter> to view the following screen:

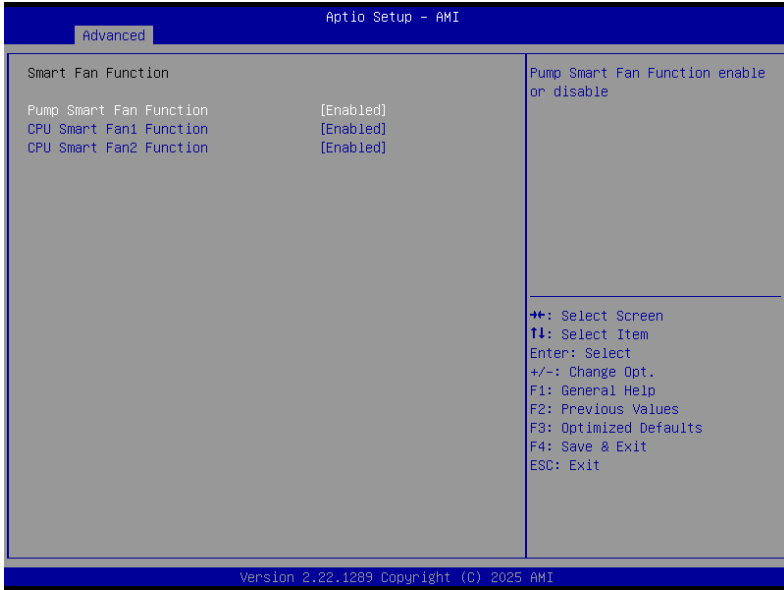

Parameter	Description
Smart Fan Function	
Pump Smart Fan Function	XXXXXXXXXXXXXX
CPU Smart Fan1 Function	XXXXXXXXXXXXXX
CPU Smart Fan2 Function	XXXXXXXXXXXXXX

2-2-3 Power Management Setup

This page sets up some parameters for system power management operation.

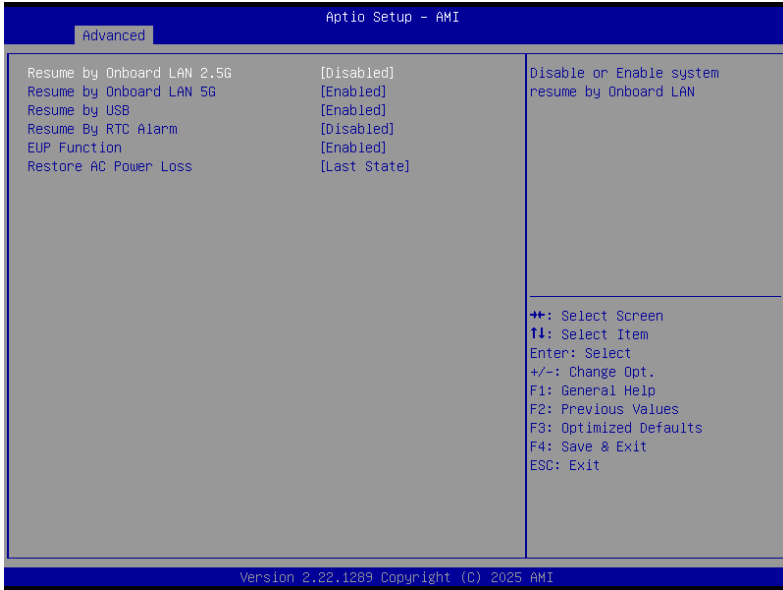

Parameter	Description
Resume by Onboard LAN 2.5G	XXXXXXXXXXXXXX
Resume by Onboard LAN 5G	XXXXXXXXXXXXXX
Resume by USB	This item allows you to enable or disable the USB device wakeup function from S3 mode.
Resume By RTC Alarm	The system can be turned off with a software command. If you enable this item, the system can automatically resume at a fixed time based on the system's RTC (realtime clock). Use the items below this one to set the date and time of the wake-up alarm. You must use an ATX power supply in order to use this feature.
EUP Function	This item allows user to enable or disable EUP support.
Resume AC Power Loss	Defines the power state to resume to after a system shutdown that is due to an interruption in AC power. When set to Last State, the system will return to the active power state prior to shutdown. When set to Power Off, the system remains off after power shutdown. Options available: Last State, Power Off, Power On, Unspecified. The default setting depends on the BMC setting.

2-2-4 CPU Configuration

The item in the menu shows the CPU Configuration.

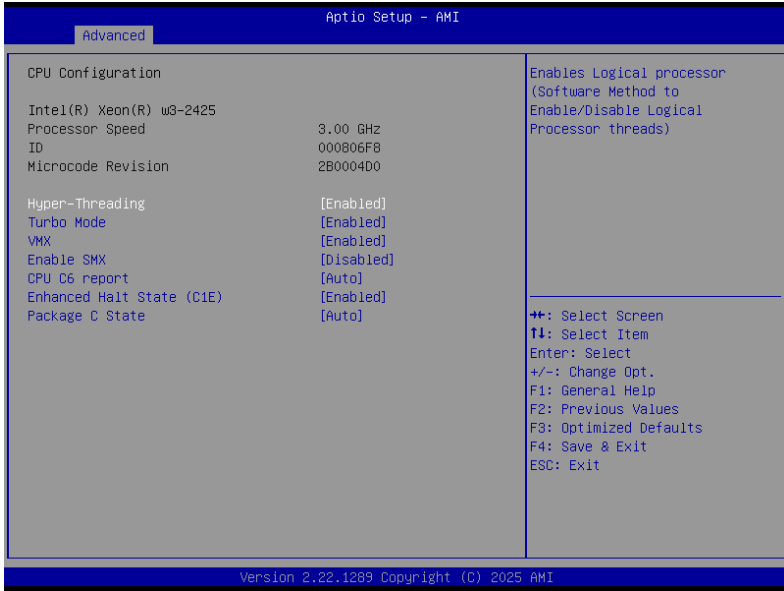

Parameter	Description
Intel(R) Xeon(R) w3-2425	This is display-only field and displays the information of the CPU installed in your computer.
Processor Speed	This item shows the processor speed.
ID	This item shows the processor ID.
Microcode Revision	This item shows the Microcode Revision.
Hyper-Threading	This item is only available when the chipset supports Hyper-Threading and you are using a Hyper-Threading CPU.
Trubo Mode	XXXXXXXXXXXXXX
VMX	This item shows the computer supports the VMX or not.
Enable SMX	This item shows the computer supports the SMX or not.
CPU c6 report	XXXXXXXXXXXXXX
Enhanced Halt State(C1E)	Use this item to enable or disable the Enhanced C1 state.
Package C State	Use this item to set the Package C State limit.

2-2-5 Trusted Computing

Use this item to show the information of trusted computing configuration.



Parameter	Description
Firmware Version/ Vendor	Displays the firmware version and Vendor information.
Security Device Support	XXXXXXXXXXXX
TPM Device Selection	Selects TPM device. Options available: dTPM, PTT. Default setting is PTT.
Active PCR banks/ Available PCR banks	PCR banks Displays active/available Platform Configuration Register (PCR) banks.
SHA256 PCR Bank	Enable/Disable SHA256 PCR bank. Options available: Disabled, Enabled. Default setting is Enabled.
SHA384 PCR Bank	Enable/Disable SHA384 PCR bank. Options available: Disabled, Enabled. Default setting is Disabled.
Pending operation	Schedule an operation for the security device. NOTE: Your computer will reboot during restart in order to change the state of a security device. Options available: None, TPM Clear. Default setting is None.
Platform Hierarchy	Enable/Disable platform hierarchy. Options available: Disabled, Enabled. Default setting is Enabled.

Storage Hierarchy	Enable/Disable storage hierarchy. Options available: Disabled, Enabled. Default setting is Enabled.
Endorsement Hierarchy	Enable/Disable endorsement hierarchy. Options available: Disabled, Enabled. Default setting is Enabled.
Physical Presence Spec Version	Selects the physical presence spec version. Options available: 1.2, 1.3. Default setting is 1.3.
Device select	Selects the TPM device. Options available: TPM 1.2, TPM 2.0, Auto. Default setting is Auto.

2-2-6 NVMe Configuration

Use this item to show the mode of NVMe configuration options.

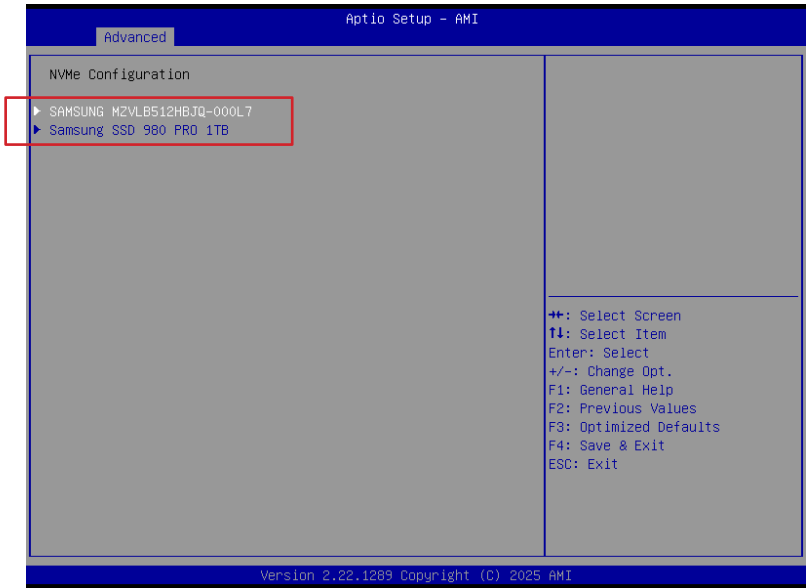

Parameter	Description
NVMe Configuration	Displays the NVMe devices connected to the system.
XXXXXXXXXXXXXX	XXXXXXXXXXXXXX
XXXXXXXXXXXXXX	XXXXXXXXXXXXXX

► **2-2-6-1 SAMSUNG MZVLB512HBQ-000L7**

XXXXXXXXXXXXXXXXXXXXXXXXXXXX:

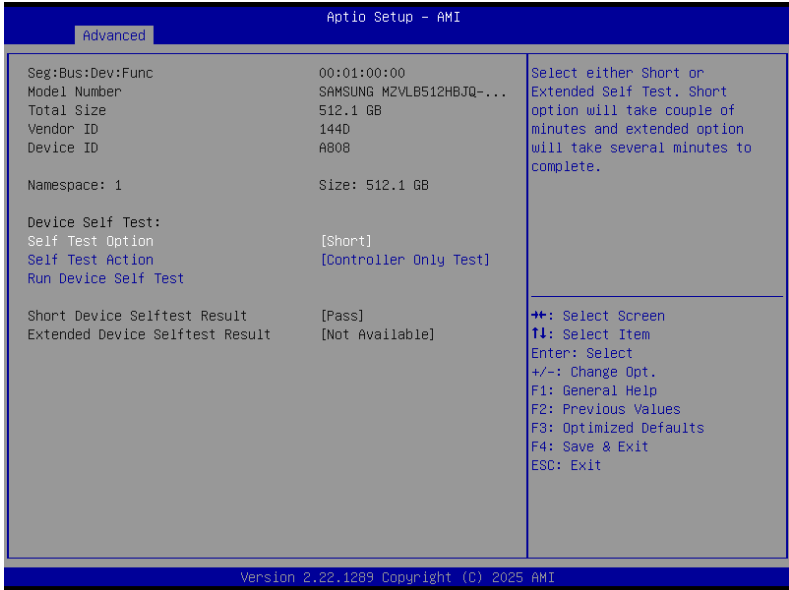

Parameter	Description
Seg:Bus:Dev:Func	XXXXXXXXXXXXXXXX
Model Number	XXXXXXXXXXXXXXXX
Total Size	XXXXXXXXXXXXXXXX
Vendor ID	
Device ID	
Namespace:1	
Device Self Text:	
self Test option	
Self test Action	
Run Device Self Test	
Short Device Selftest Result	
Extended Device Selftest Result	

?

► **2-2-6-2 SAMSUNG SSD980 PRO 1TB**

XXXXXXXXXXXXXXXXXXXXXXXXXXXX:



Parameter	Description
Seg:Bus:Dev:Func	XXXXXXXXXXXXXX
Model Number	XXXXXXXXXXXXXX
Total Size	XXXXXXXXXXXXXX
Vendor ID	
Device ID	
Namespace:1	
Device Self Text:	
self Test option	
Self test Action	
Run Device Self Test	
Short Device Selftest Result	
Extended Device Selftest Result	

2-2-7 USB Configuration

Use this item to show the information of USB configuration.

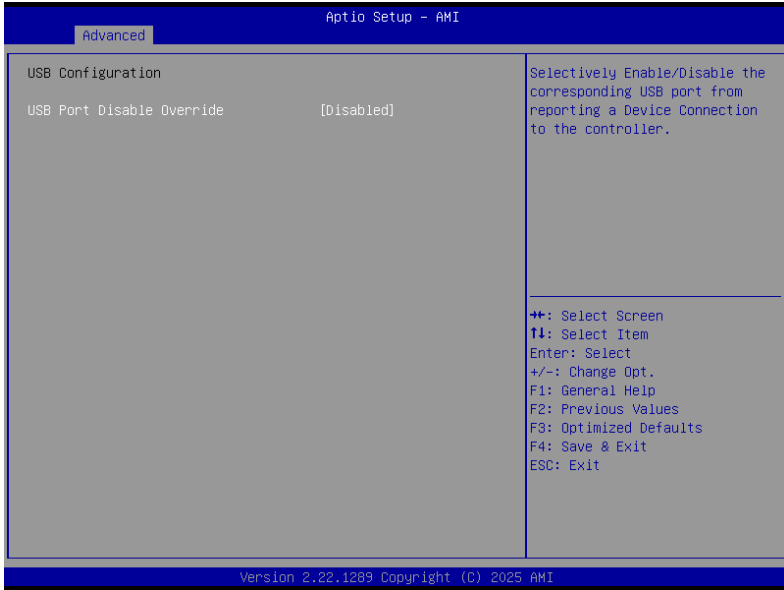

Parameter	Description
USB Configuration	
USB Port Disable Override	XXXXXXXXXXXXX

2-2-8 IIO PCIe Configuration

XXXXXXXXXXXXXXXXXXXXXXXXXXXXXXXXXXXX.

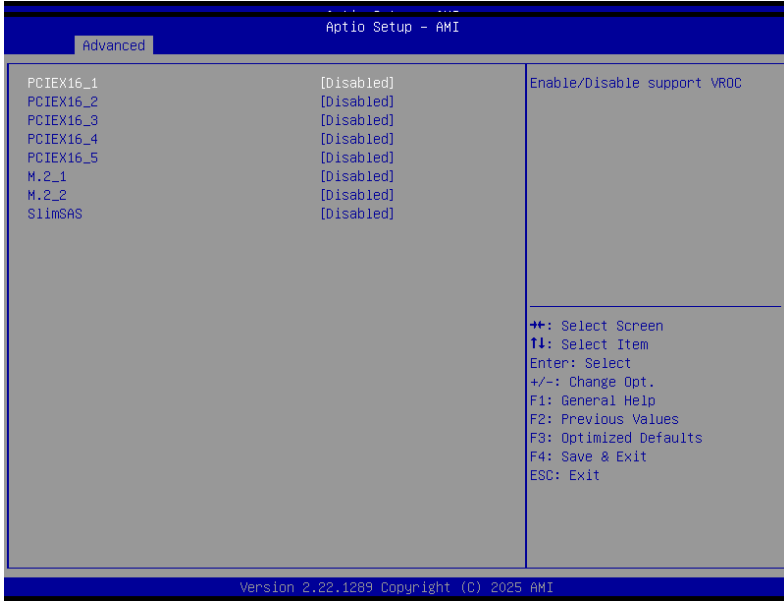

2-2-9 VROC StorageConfiguration

XXXXXXXXXXXXXXXXXXXXX.

Advanced Aptio Setup - AMI

Seg:Bus:Dev:Func Model Number Total Size Vendor ID Device ID Namespace: 1 Device Self Test: Self Test Option Self Test Action Run Device Self Test Short Device Selftest Result Extended Device Selftest Result	00:01:00:00 SAMSUNG M2VLB512HBJQ-... 512.1 GB 144D A808 Size: 512.1 GB [Short] [Controller Only Test] [Pass] [Not Available]	Select either Short or Extended Self Test. Short option will take couple of minutes and extended option will take several minutes to complete. ++: Select Screen F1: Select Item Enter: Select +/-: Change Opt. F1: General Help F2: Previous Values F3: Optimized Defaults F4: Save & Exit ESC: Exit
--	---	--

Version 2.22.1289 Copyright (C) 2025 AMI

Parameter	Description
XXXXXXXXXXXXXXXXXX	XXXXXXXXXXXXXXXXXX
XXXXXXXXXXXXXXXXXX	XXXXXXXXXXXXXXXXXX

2-2-10 MEBX

XXXXXXXXXXXXXXXXXXXXXX.

Advanced Aptio Setup - AMI		
Seg:Bus:Dev:Func	00:01:00:00	Select either Short or Extended Self Test. Short option will take couple of minutes and extended option will take several minutes to complete.
Model Number	SAMSUNG M2VLB512HBJQ-...	
Total Size	512.1 GB	
Vendor ID	144D	
Device ID	A808	
Namespace: 1	Size: 512.1 GB	
Device Self Test:		
Self Test Option	[Short]	
Self Test Action	[Controller Only Test]	
Run Device Self Test		
Short Device Selftest Result	[Pass]	++: Select Screen f1: Select Item Enter: Select +/-: Change Opt. F1: General Help F2: Previous Values F3: Optimized Defaults F4: Save & Exit ESC: Exit
Extended Device Selftest Result	[Not Available]	

Version 2.22.1289 Copyright (C) 2025 AMI

Parameter	Description
XXXXXXXXXXXXXX	XXXXXXXXXXXXXX
XXXXXXXXXXXXXX	XXXXXXXXXXXXXX

2-3 Platform Configuration Menu

XXXXXXXXXXXXXXXXXXXXXXXXXXXXXXXXXXXX.

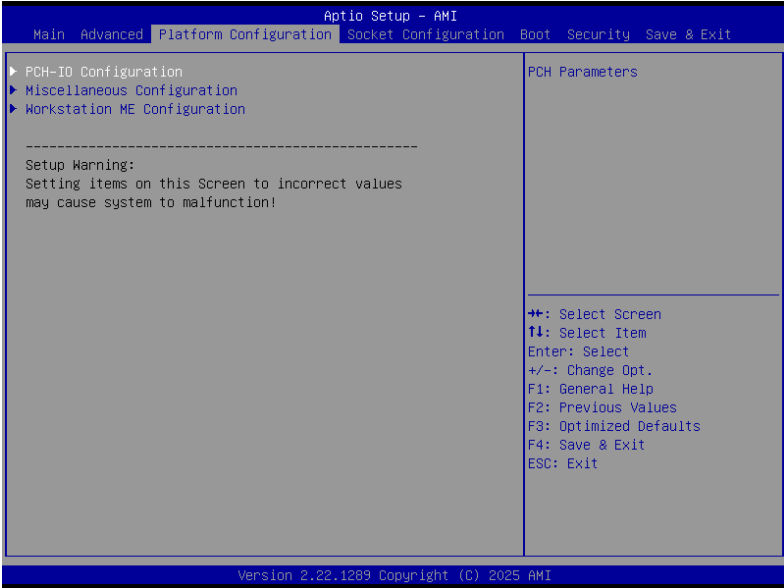

2-3-1 PCH-IO Configuration

XXXXXXXXXXXXXXXXXXXXXXXXXXXXXXXXXXXX.



► 2-3-1-1 SATA Configuration

Press [Enter] to configure advanced items.

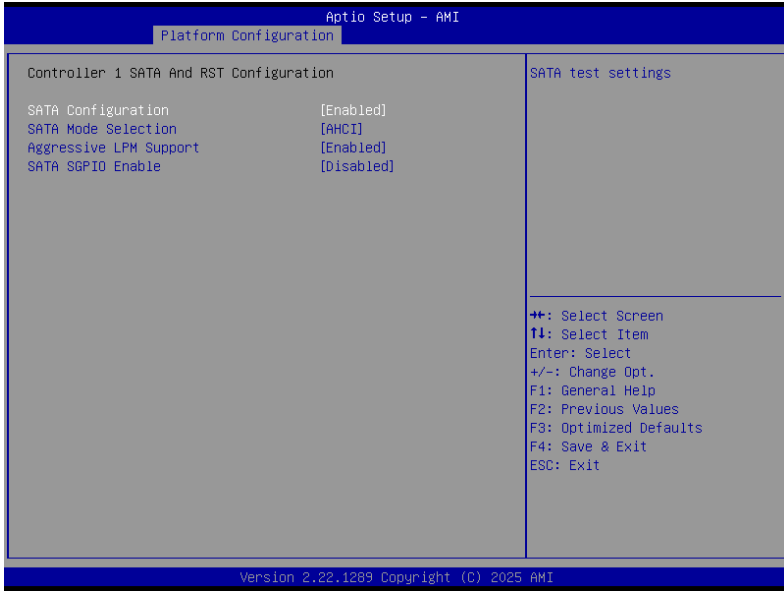

Parameter	Description
SATA Configuration	<ul style="list-style-type: none"> – Enable/Disable SATA controller. – Options available: Enabled, Disabled. Default setting is Enabled.
SATA Mode Selection	<ul style="list-style-type: none"> – Configures on chip SATA type. – AHCI Mode: When set to AHCI, the SATA controller enables its AHCI functionality. Then the RAID function is disabled and cannot be access the RAID setup utility at boot time. – RAID Mode: When set to RAID, the SATA controller enables both its RAID and AHCI functions. You will be allowed to access the RAID setup utility at boot time. – Options available: AHCI, RAID. Default setting is AHCI.
Aggressive LPM Support	XXXXXXXXXXXX
SATA SGPIO Enable	

► **2-3-1-2 HD Audio Configuration**

XXXXXXXXXXXXXXXXXXXXXXXXXXXXXXXXXXXX.



Parameter	Description
HD Audio	This item enables or disables Azalia HD audio.

2-3-2 Miscellaneous Configuration

XXXXXXXXXXXXXXXXXXXXXXXXXXXXXXXXXXXX.

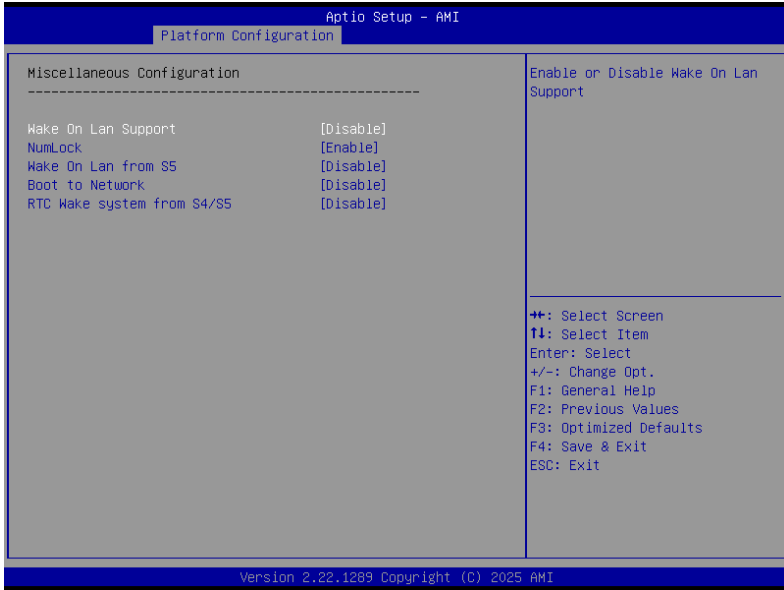

Parameter	Description
Wake On Lan Support	XXXXXXXXXXXXXX
NumLock	Enable/Disable the Bootup NumLock function. Options available: On, Off. Default setting is On.
Wake On Lan from S5	XXXXXXXXXXXXXX
Boot to Network	XXXXXXXXXXXXXX
RTC wake system from S4/S5	XXXXXXXXXXXXXX

2-3-3 Workstation ME Configuration

XXXXXXXXXXXXXXXXXXXXXXXXXXXXXXXXXXXX.



Parameter	Description
ME Firmware Version	Displays the operational firmware version.
ME Firmware Mode	Displays the operational firmware mode.
ME Firmware SKU	Disaplays ME firmware sku information.
AMT BIOS Features	XXXXXXXXXXXXXX

2-4 Socket Configuration Menu

XXXXXXXXXXXXXXXXXXXXXXXXXXXXXXXXXXXX.



2-4-1 Processor Configuration

XXXXXXXXXXXXXXXXXXXXXXXXXXXXXXXXXXXX

The screenshot displays the 'Aptio Setup - AMI' interface, specifically the 'Socket Configuration' menu. The main area is titled 'Processor Configuration' and contains a list of system parameters. A vertical scrollbar is visible on the right side of this list. To the right of the main list is a legend for navigation keys.

Processor Configuration	

▶ Per-Socket Configuration	
Processor BSP Revision	806F8 - SPR-SP S3
Processor Socket	Socket 0
Processor ID	000806F8*
Processor Frequency	3.000GHz
Processor Max Ratio	1EH
Processor Min Ratio	08H
Microcode Revision	2B0004D0
L1 Cache RAM(Per Core)	80KB
L2 Cache RAM(Per Core)	2048KB
L3 Cache RAM(Per Package)	15360KB
Processor 0 Version	
Intel(R) Xeon(R) w3-242	
Enable LP [Global]	[ALL LPs]
Hardware Prefetcher	[Enable]
Adjacent Cache Prefetch	[Enable]
DCU Streamer Prefetcher	[Enable]
DCU IP Prefetcher	[Enable]
LLC Prefetch	[Disable]
Homeless Prefetch	[Auto]
Extended APIC	[Disable]
Enable Intel(R) TXT	[Disable]

Change Per-Socket Settings

- ++: Select Screen
- f1: Select Item
- Enter: Select
- +/-: Change Opt.
- F1: General Help
- F2: Previous Values
- F3: Optimized Defaults
- F4: Save & Exit
- ESC: Exit

Version 2.22.1289 Copyright (C) 2025 AMI

► 2-4-1-1 Per-Socket Configuration

Press [Enter] to configure advanced items.

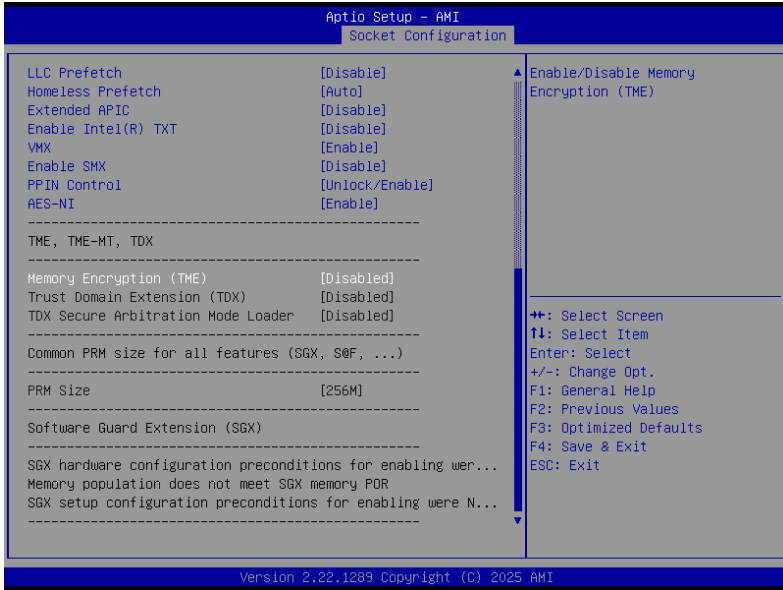

Parameter	Description
Homeless Prefetch	XXXXXXXXXXXXXX
Extended APIC	Enable/Disable extended APIC support. Note: The VT-d will be enabled automatically when x2APIC is enabled. Options available: Enable, Disable. Default setting is Enable.
Enable Intel(R) TXT	Enable/Disable the Intel Trusted Execution Technology support function. Options available: Enable, Disable. Default setting is Disable.
VMX	Enable/Disable the Vanderpool Technology. This will take effect after rebooting the system. Options available: Enable, Disable. Default setting is Enable.
Enable SMX	Enable/Disable the Safer Mode Extensions (SMX) support function. Options available: Enable, Disable. Default setting is Disable.
PPIN Control	XXXXXXXXXXXXXX
AES-NI	Enable/Disable the AES-NI support. Options available: Enable, Disable. Default setting is Enable.

Memory Encryption	Enable/Disable memory encryption (TME). Options available: Enabled, Disabled. Default setting is Disabled.
Trust Domain Extension	XXXXXXXXXXXXX
TDX Secure Arbitration Mode Loader	XXXXXXXXXXXXX
PRM Size	XXXXXXXXXXXXX
Software Guard Extension	XXXXXXXXXXXXX

2-4-2 Uncore Configuration

XXXXXXXXXXXXXXXXXXXXXXXXXXXXXXXXXXXX.

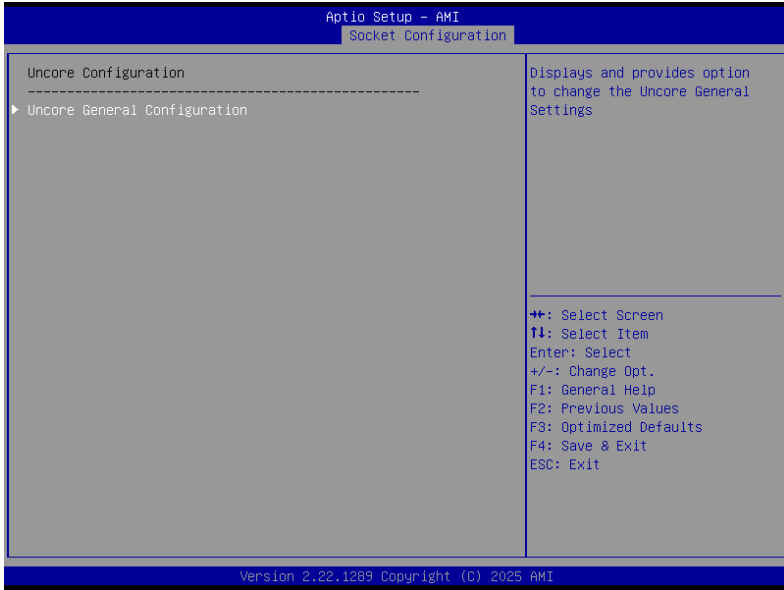

► 2-4-2-1 Uncore General Configuration

XXXXXXXXXXXXXXXXXXXXXXXXXXXXXXXXXXXX.

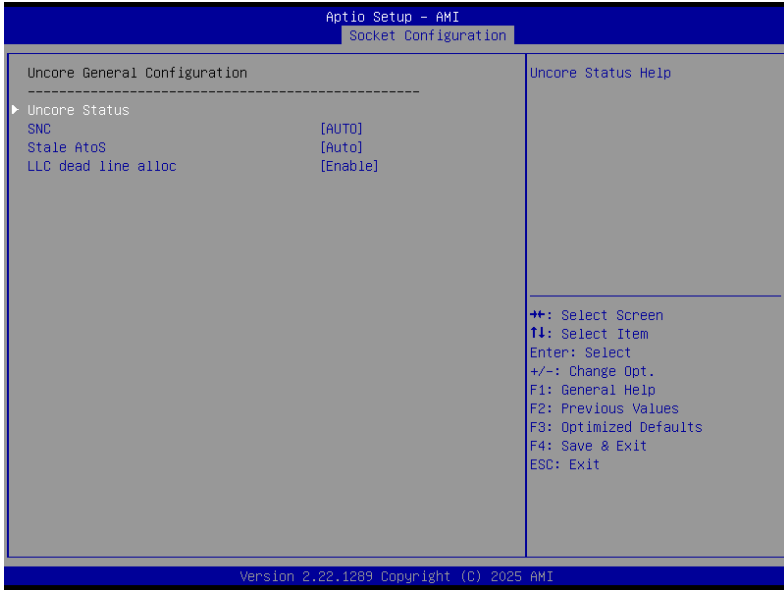

► Uncore General Configuration

XXXXXXXXXXXXXXXXXXXXXXXXXXXXXXXXXXXX.

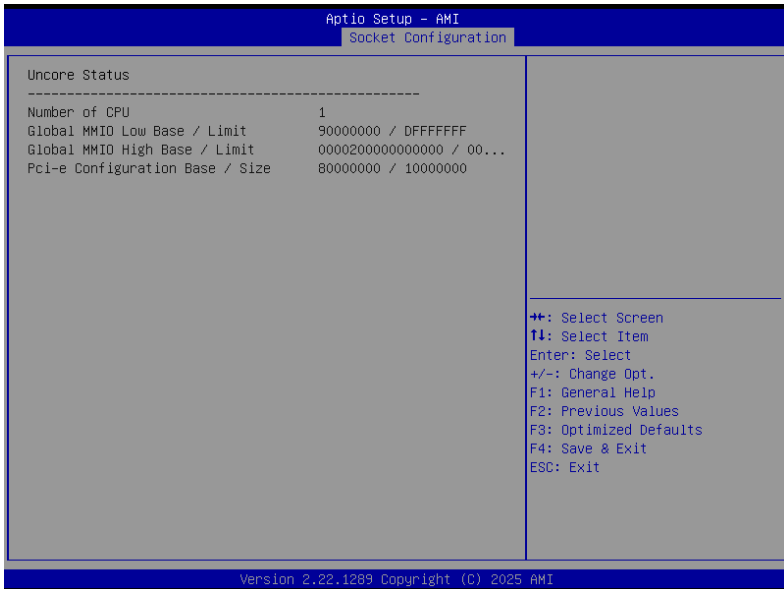

2-4-3 Memory Configuration

XXXXXXXXXXXXXXXXXXXXXXXXXXXXXXXXXXXX.

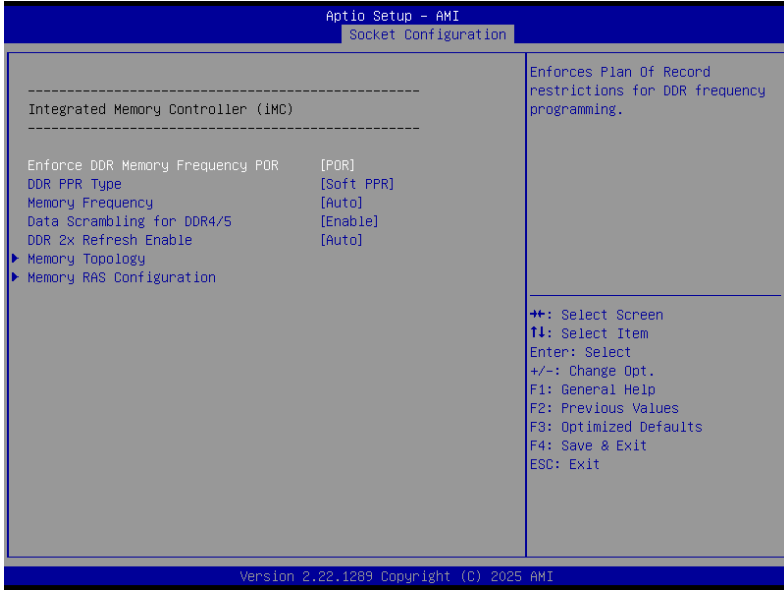

Parameter	Description
Integrated Memory Controller (iMC)	
Enforce DDR Memory Frequency POR	When set to Enable, the system enforces Plan Of Record restrictions for DDR frequency programming. Options available: POR, Disable. Default setting is POR.
DDR PPR Type	XXXXXXXXXXXXXX
Memory Frequency	Configures the maximum memory frequency. If Enforce POR is disabled, user will be able to run at higher frequencies than the memory support (limited by processor support). Default setting is Auto.
Data Scrambling for DDR4/5	XXXXXXXXXXXXXX
DDR 2X Refresh Enable	XXXXXXXXXXXXXX

► 2-4-3-1 Memory Topology

Press [Enter] to view memory topology with DIMM population information.

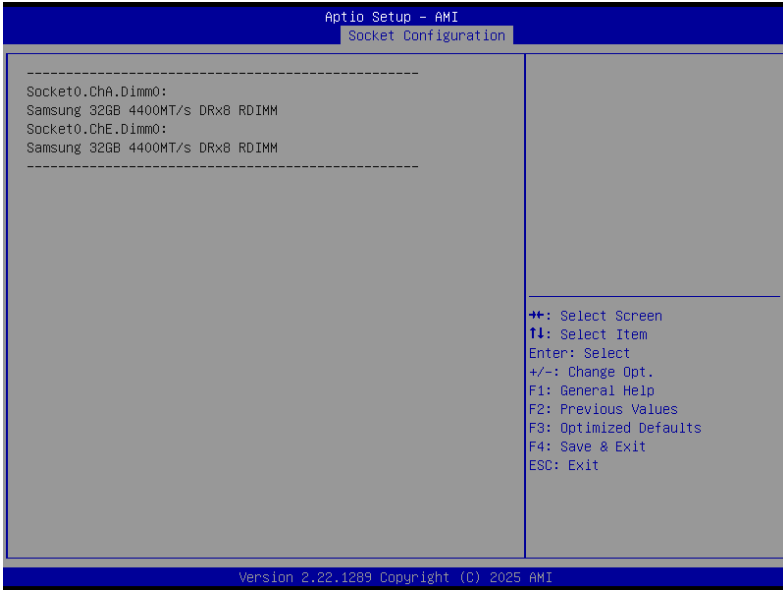

► 2-4-3-2 Memory RAS Configuration Setup

Press [Enter] to configure advanced items.

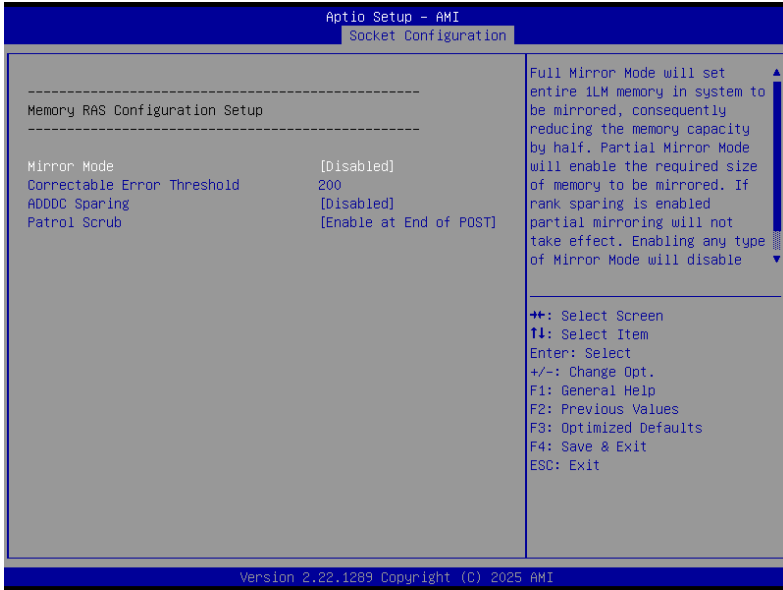

Parameter	Description
Mirror Mode	<ul style="list-style-type: none"> – Mirror Mode will set entire 1LM memory in system to be mirrored, consequently reducing the memory capacity by half. Enables the Mirror Mode will disable the XPT Prefetch. – Options available: Disabled, Full Mirror Mode, Partial Mirror Mode. Default setting is Disabled.
Correctable Error Threshold	<ul style="list-style-type: none"> – Correctable Error Threshold (0x01-0x7fff) used for sparing, and leaky bucket. – Press the <+> / <-> keys to increase or decrease the desired values.
ADDDC Sparing	<ul style="list-style-type: none"> – Enable/Disable ADDDC Sparing. – Options available: Disabled, Enabled. Default setting is Disabled.
Patrol Scrub	<ul style="list-style-type: none"> – Options available: Disabled, Enable at End of POST. Default setting is Enable at End of POST.

2-4-4 IIO Configuration

XXXXXXXXXXXXXXXXXXXXXXXXXXXXXXXXXXXX.

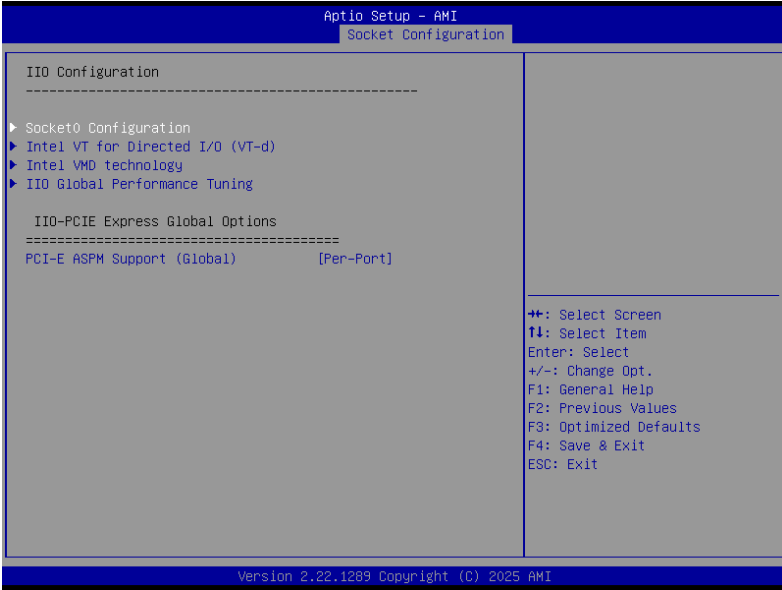

► 2-4-4-1 Socket0 Configuration

XXXXXXXXXXXXXXXXXXXXXXXXXXXXXXXXXXXX.

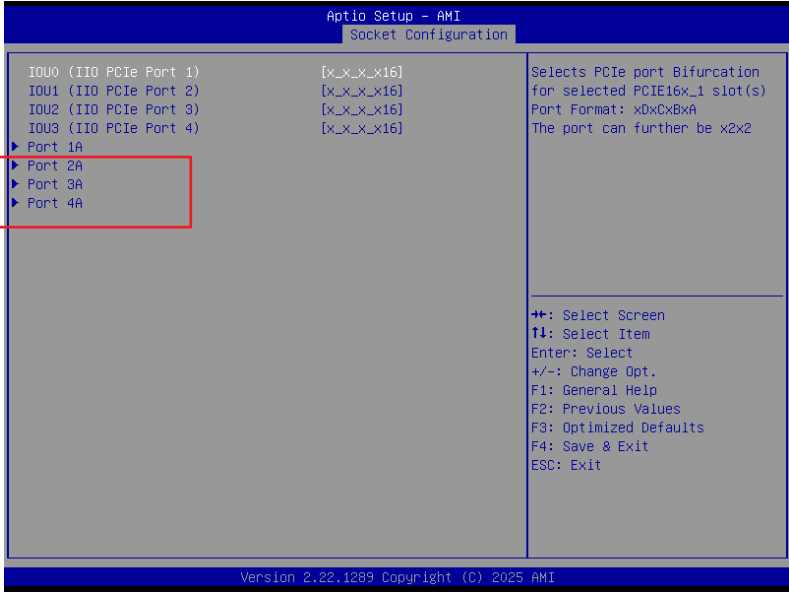

Parameter	Description
IOU0 (IIO PCIe Port 1)	XXXXXXXXXXXXXXXX
IOU1 (IIO PCIe Port 2)	XXXXXXXXXXXXXXXX
IOU2 (IIO PCIe Port 3)	XXXXXXXXXXXXXXXX
IOU3 (IIO PCIe Port 4)	XXXXXXXXXXXXXXXX

> Port 1A

XXXXXXXXXXXXXXXXXXXXXXXXXXXXXXXXXXXX.

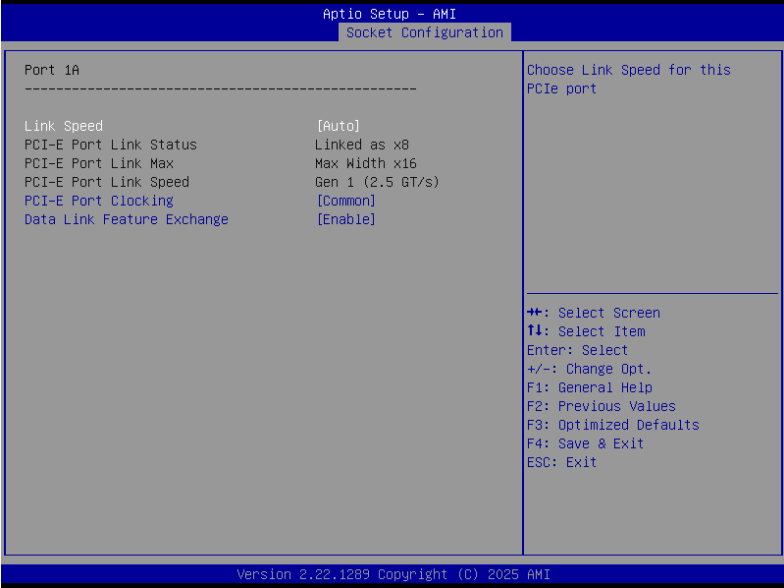

Parameter	Description
Link Speed	XXXXXXXXXXXXXXXX
PCI-E Port Link Status	XXXXXXXXXXXXXXXX
PCI-E Port Link Max	XXXXXXXXXXXXXXXX
PCI-E Port Link Speed	XXXXXXXXXXXXXXXX
PCI-E Port Link Clocking	XXXXXXXXXXXXXXXX
Data Link Feature Exchange	XXXXXXXXXXXXXXXX

► 2-4-4-2 Intel VT for Directed I/O (VT-d)

Press [Enter] to configure advanced items.

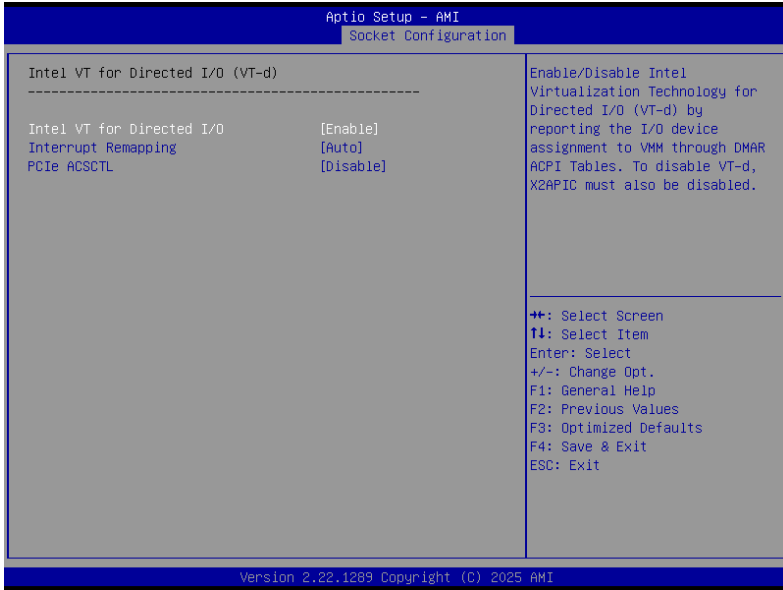

Parameter	Description
Intel VT for Directed I/O	<ul style="list-style-type: none"> – Enable/Disable the Intel VT for Directed I/O (VT-d) support function by reporting the I/O device assignment to VMM through DMAR ACPI Tables. – Options available: Enable, Disable. Default setting is Enable.
Interrupt Remapping	<ul style="list-style-type: none"> – Enable/Disable the interrupt remapping support function. – Options available: Auto, Enable, Disable. Default setting is Auto
PCIe ACSCTL	<ul style="list-style-type: none"> – Options available: Enable, Disable. Default setting is Disable.

► 2-4-4-3 Intel VMD technology

XX.

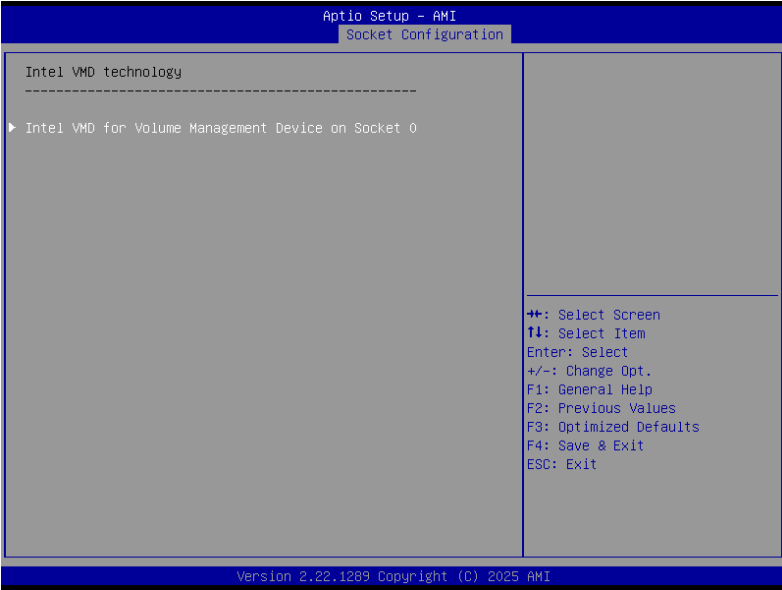

► Intel VMD for Volume Management Device on Socket 0

XXXXXXXXXXXXXXXXXXXXXXXXXXXXXXXXXXXXX.

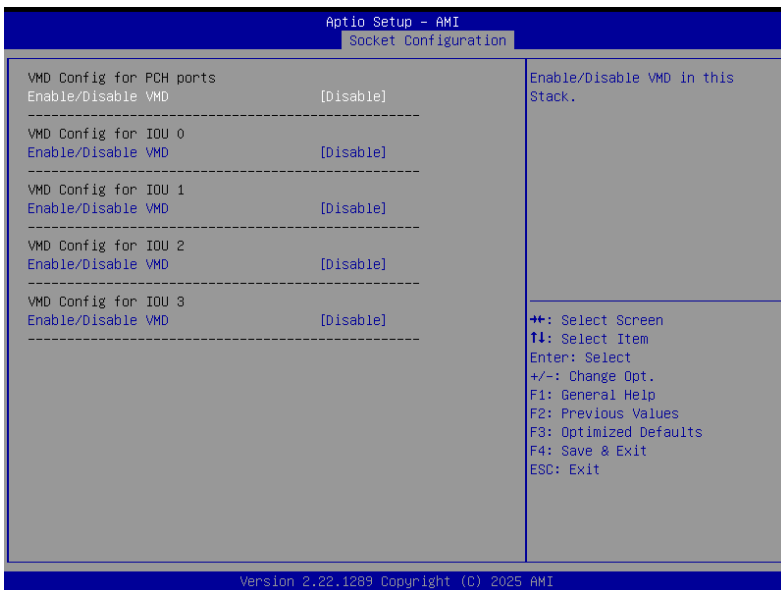

Parameter	Description
VMD Config for PCH ports	XXXXXXXXXXXXXX
VMD Config for IOU 0	XXXXXXXXXXXXXX
VMD Config for IOU 1	XXXXXXXXXXXXXX
VMD Config for IOU 2	XXXXXXXXXXXXXX
VMD Config for IOU 3	XXXXXXXXXXXXXX

► **2-4-4-4 Intel Global Performane Tuning**

XXXXXXXXXXXXXXXXXXXXXXXXXXXXXXXXXXXX.

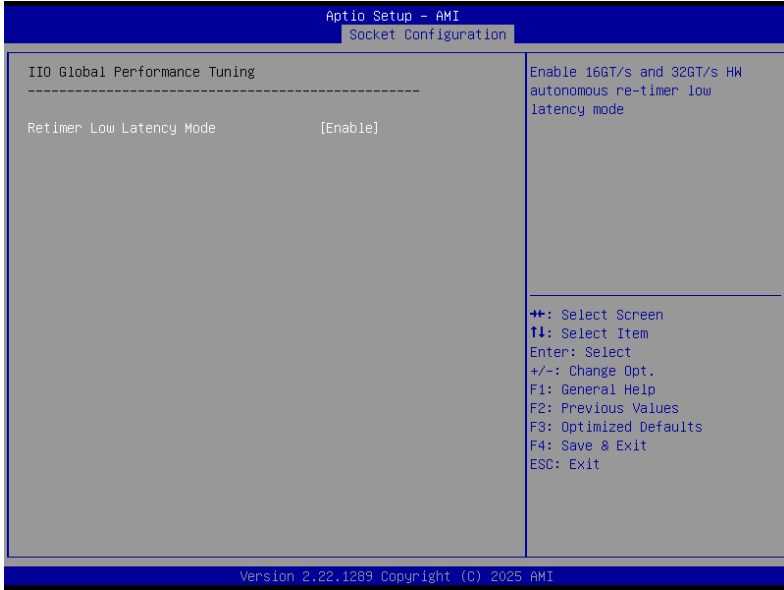

Parameter	Description
REtimer Low Latency Mode	XXXXXXXXXXXXXX

2-4-5 Advanced Power Management Configuration

Press [Enter] to configure advanced items.

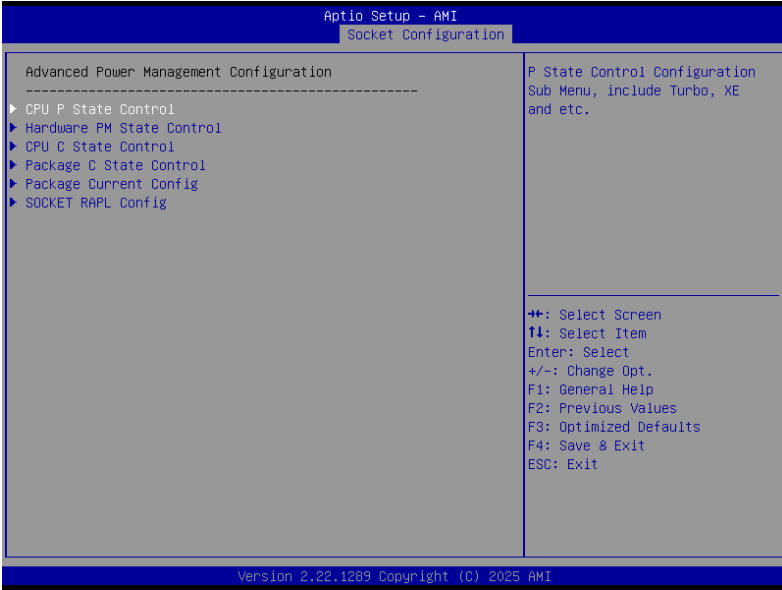

► 2-4-5-1 CPU P State Control

Press [Enter] to configure advanced items.

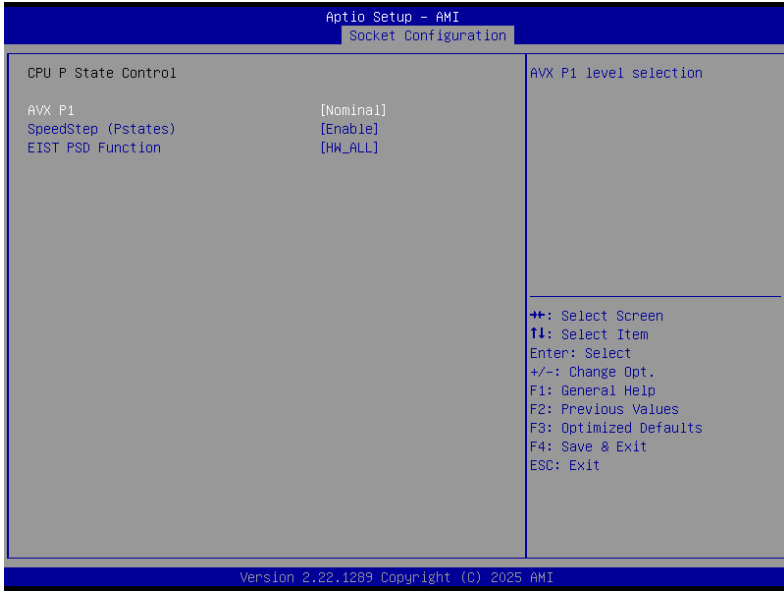

Parameter	Description
AVX P1	XXXXXXXXXXXXXX
SpeedStep (Pstates)	<ul style="list-style-type: none"> – Conventional Intel SpeedStep Technology switches both voltage and frequency in tandem between high and low levels in response to processor load. – Options available: Enable, Disable. Default setting is Enable.
EIST PSD Function	XXXXXXXXXXXXXX

► 2-4-5-2 Hardware PM State Control

Press [Enter] to configure advanced items.



Parameter	Description
Hardware P-States	<ul style="list-style-type: none"> – When this item is disabled, the processor hardware chooses a P-state based on OS Request (Legacy P-States). – In Native mode, the processor hardware chooses a P-state based on OS guidance. – In Out of Band mode, the processor hardware autonomously chooses a P-state (with no OS guidance). – Options available: Disable, Native Mode, Out of Band Mode, Native Mode with No Legacy Support. Default setting is Native Mode.

► 2-4-5-3 CPU C State Control

Press [Enter] to configure advanced items.

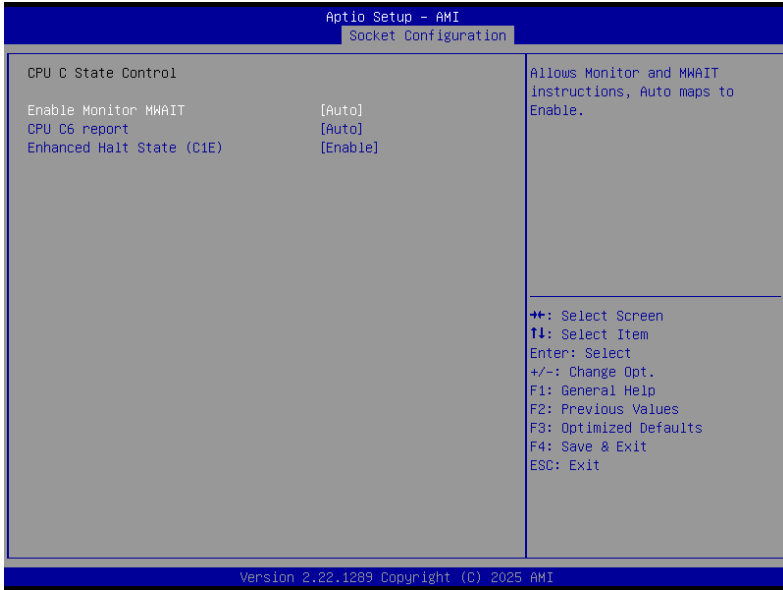

Parameter	Description
Enable Monitor MWAIT	<ul style="list-style-type: none"> Allows Monitor and MWAIT instructions. Options available: Disable, Enable, Auto. Default setting is Auto.
CPU C6 repor1	<ul style="list-style-type: none"> Enable/Disable CPU C6(ACPI C3) report to OS. Options available: Disable, Enable, Auto. Default setting is Auto.
Enhanced Halt State (C1E)	<ul style="list-style-type: none"> Core C1E auto promotion control. Takes effect after reboot. Options available: Enable, Disable. Default setting is Enable.

► 2-4-5-4 Package C State Control

Press [Enter] to configure advanced items.

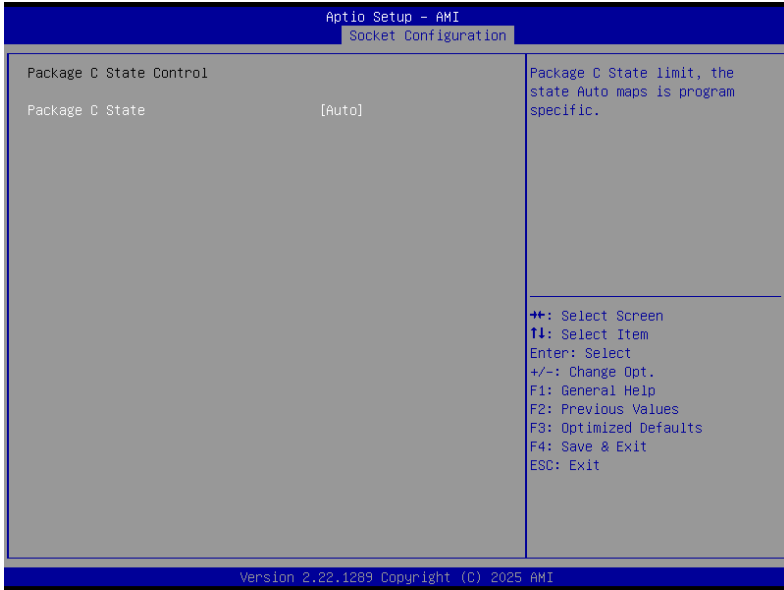

Parameter	Description
Package C Stat	<ul style="list-style-type: none">– Configures the state for the C-State package limit.– Options available: C0/C1 state, C2 state, C6(non Retention) state, C6(Retention) state, No Limit, Auto. Default setting is Auto.

► **2-4-5-5 Package Current Config**

XXXXXXXXXXXXXXXXXXXXXXXXXXXXXXXXXXXX.

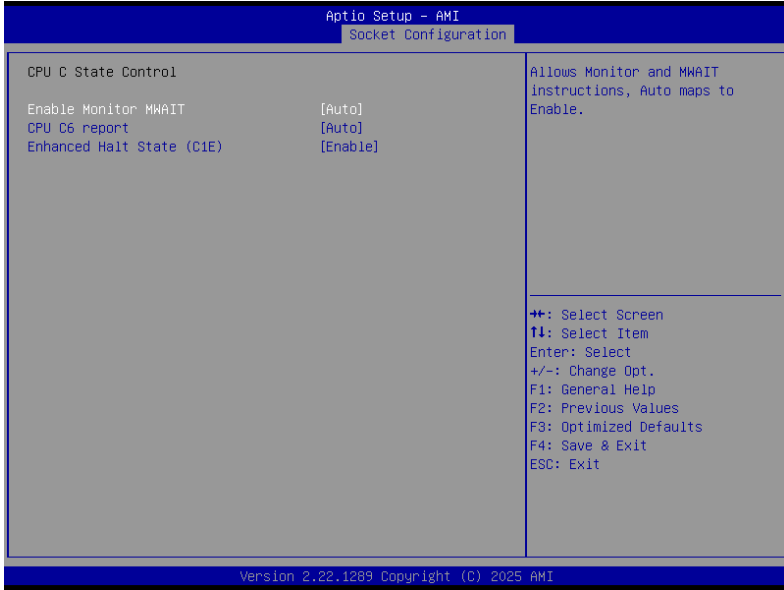

Parameter	Description
Current Limit Override	XXXXXXXXXXXXXX
Lock Indication	XXXXXXXXXXXXXX

► **2-4-5-6 SOCKET RAPL Config**

XXXXXXXXXXXXXXXXXXXXXXXXXXXXXXXXXXXX.

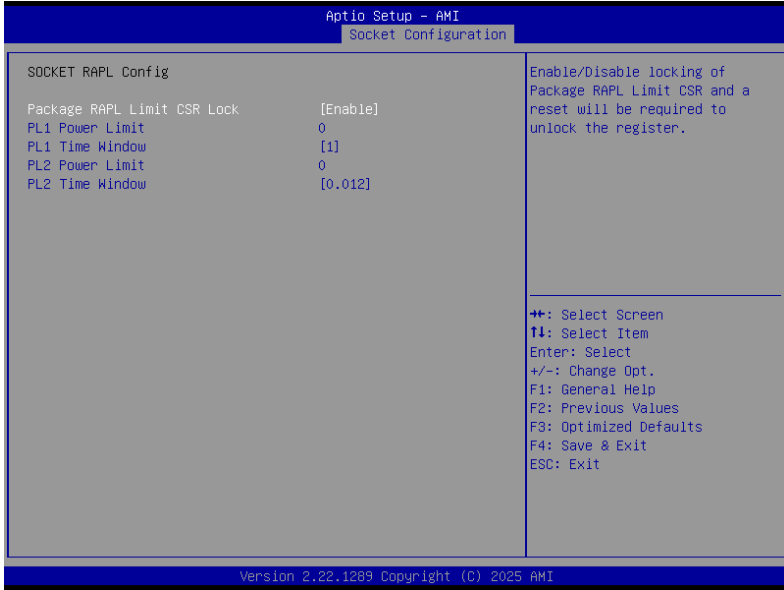

Parameter	Description
Package RAPL Limit CSR Lock	XXXXXXXXXXXXXXXX
PL1 Power Limit	XXXXXXXXXXXXXXXX
PL1 Time Window	XXXXXXXXXXXXXXXX
PL2 Power Limit	XXXXXXXXXXXXXXXX
PL2 Time Window	XXXXXXXXXXXXXXXX

2-5 Boot Menu

The Boot menu allows you to set the drive priority during system boot-up. BIOS setup will display an error message if the legacy drive(s) specified is not bootable.

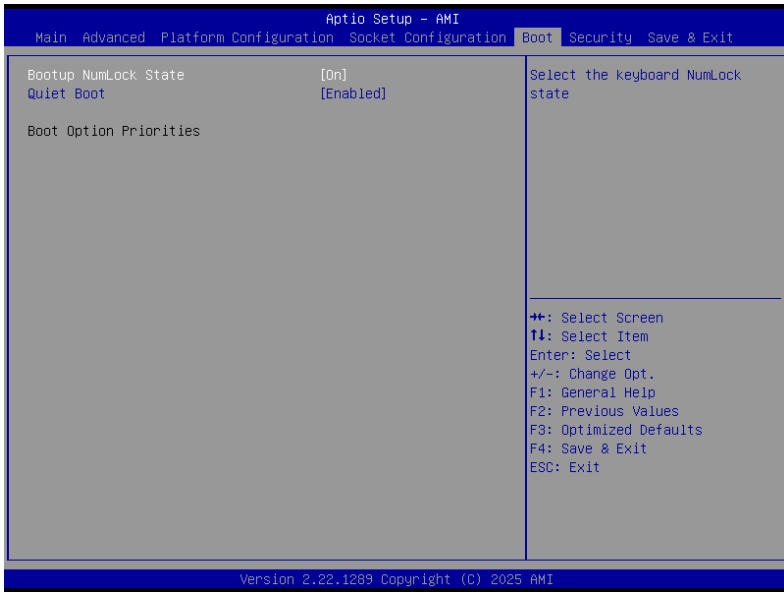

Parameter	Description
Bootup NumLock State	Enable/Disable the Bootup NumLock function. Options available: On, Off. Default setting is On.
Quiet Boot	Enable/Disable showing the logo during POST. Options available: Enabled, Disabled. Default setting is Enabled.
Boot Option Priorities	These items show the boot priorities.

2-6 Security Menu

The Security menu allows you to safeguard and protect the system from unauthorized use by setting up access passwords.

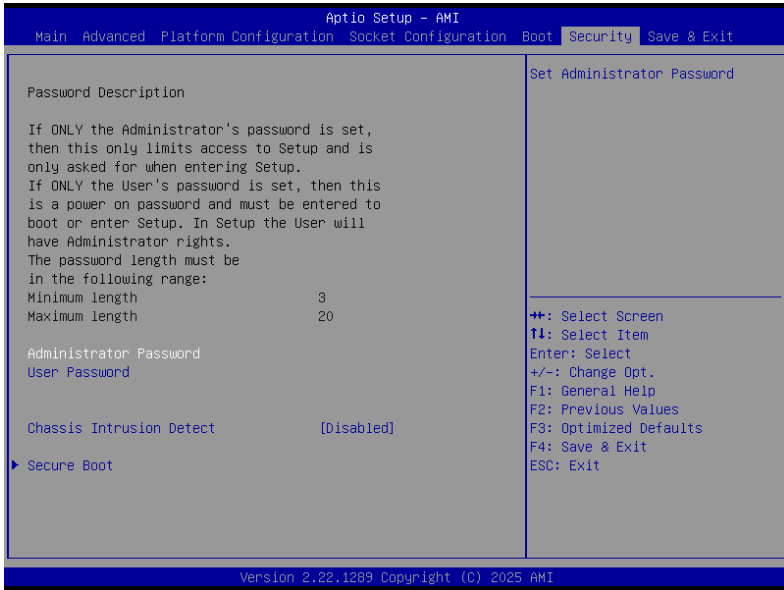

Parameter	Description
Password Description	XXXXXXXXXXXXXXXX
Minimum length	XXXXXXXXXXXXXXXX
Maximum length	XXXXXXXXXXXXXXXX
Administrator Password	Entering this password will allow the user to access and change all settings in the Setup Utility.
User Password	Entering this password will restrict a user's access to the Setup menus. To enable or disable this field, a Administrator Password must first be set. A user can only access and modify the System Time, System Date, and Set User Password fields.
Chassis Intrusion Detect	This detects if the chassis cover has been removed. This function needs a chassis equipped with intrusion detection switch and needs to be enabled in BIOS.

► 2-6-1 Secure Boot

The Secure Boot submenu is applicable when your device is installed the Windows® 8 (or above) operating system.



Parameter	Description
System Mode state	Displays if the system is in User mode or Setup mode.
Secure Boot	Enable/Disable the Secure Boot function. Options available: Enabled, Disabled. Default setting is Disabled.
Secure Boot mode	Secure Boot requires all the applications that are running during the booting process to be pre-signed with valid digital certificates. This way, the system knows all files being loaded before Windows loads to the login screen have not been tampered with. When set to Standard, it will automatically load the Secure Boot keys from the BIOS databases. When set to Custom, you can customize the Secure Boot settings and manually load its keys from the BIOS database. Options available: Standard, Custom. Default setting is Custom.
Restore Factory Keys	Forces the system to user mode and installs factory default Secure Boot key database.
Reset To Setup Mode	Reset the system to Setup Mode.
Enter Audit Mode	XXXXXXXXXXXXXX
Enter Deployed Mode	XXXXXXXXXXXXXX

Press [Enter] to configure advanced items.

Please note that this item is configurable when Secure Boot Mode is set to Custom.

- Factory Key Provision
 - Allows to provision factory default Secure Boot keys when system is in Setup Mode.
 - Options available: Enabled, Disabled. Default setting is Disabled.
 - Restore Factory Keys
 - Installs all factory default keys. It will force the system in User Mode.
 - Options available: Yes, No.
 - Reset To Setup Mode
 - Reset the system to Setup Mode.
 - Options available: Yes, No.
 - Enroll Efi Image
 - Press [Enter] to enroll SHA256 hash of the binary into Authorized Signature Database (db).
 - Export Secure Boot variables
 - Copy NVRAM content of Secure Boot variables to files in a root folder on a file system device.
 - Secure Boot variable
 - Displays the current status of the variables used for secure boot.
 - Platform Key (PK)
 - Displays the current status of the Platform Key (PK).
 - Press [Enter] to configure a new PK.
 - Options available: Update.
 - Key Exchange Keys (KEK)
 - Displays the current status of the Key Exchange Key Database (KEK).
 - Press [Enter] to configure a new KEK or load additional KEK from storage devices.
 - Options available: Update, Append.
 - Authorized Signatures (DB)
 - Displays the current status of the Authorized Signature Database.
 - Press [Enter] to configure a new DB or load additional DB from storage devices.
 - Options available: Update, Append.
 - Forbidden Signatures (DBX)
 - Displays the current status of the Forbidden Signature Database.
 - Press [Enter] to configure a new dbx or load additional dbx from storage devices.
 - Options available: Update, Append.
-

Key Management
(continued)

- Authorized TimeStamps (DBT)
 - Displays the current status of the Authorized TimeStamps Database.
 - Press [Enter] to configure a new DBT or load additional DBT from storage devices.
 - Options available: Update, Append.
 - OsRecovery Signatures
 - Displays the current status of the OsRecovery Signature Database.
 - Press [Enter] to configure a new OsRecovery Signature or load additional OsRecovery Signature from storage devices.
 - Options available: Update, Append.
-

2-7 Save & Exit Menu

The Save & Exit menu displays the various options to quit from the BIOS setup. Highlight any of the exit options then press <Enter>.

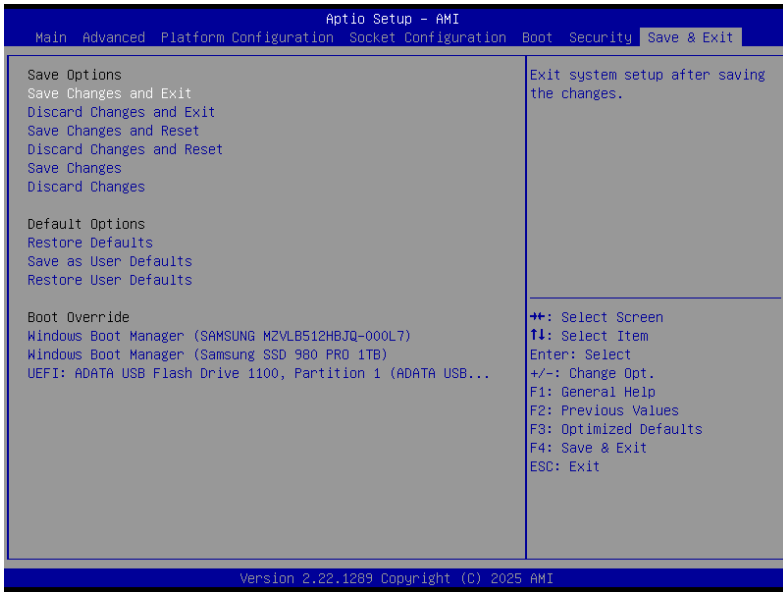

Parameter	Description
Save Changes and Exit	Saves changes made and closes the BIOS setup. Options available: Yes, No.
Discard changes and Exit	Discards changes made and exits the BIOS setup. Options available: Yes, No.
Save Changes and Reset	Restarts the system after saving the changes made. Options available: Yes, No.
Discard Changes and Reset	Restarts the system without saving any changes. Options available: Yes, No.
Save Changes	Saves changes done so far to any of the setup options. Options available: Yes, No.
Discard Changes	Discards changes made and closes the BIOS setup. Options available: Yes, No.
Restore Default	Loads the default settings for all BIOS setup parameters. Setup Defaults are quite demanding in terms of resources consumption. If you are using low-speed memory chips or other kinds of low-performance components and you choose to load these settings, the system might not function properly. Options available: Yes, No.

Save the User Default	Saves the changes made as the user default settings. Options available: Yes, No.
Restore the User Default Values	Loads the user default settings for all BIOS setup parameters. Options available: Yes, No.
Boot Override	Use this item to select the boot device.

設定系統

安裝前需求

選擇擺置地點

在拆開和安裝系統之前，請先選擇一個適當的擺置地點，如此可讓系統發揮最大效益。選擇地點時，請考慮下列因素：

- 靠近接地電源插座。
- 乾淨且無塵。
- 堅固且不會震動的表面。
- 通風良好且遠離熱源。
- 遠離電子裝置（例如空調機、收音機和電視傳輸器等）所產生的電磁場。

檢查包裝盒內容

請先檢查下列包裝盒中的產品項目：

- 系統
- 配件盒

上述的任何一項物品若有損壞或缺失，應盡速與經銷商聯絡。

請妥善保存所有產品包裝盒與其他包材，以利未來運送時使用。

打開系統電源

確認系統安裝正確，使用合適電源，並且已連接所有必需週邊設備後，即可打開電腦電源。請依照以下步驟進行。

按下電源按鈕。

系統開始啟動並顯示歡迎訊息。然後，會出現連續的開機自我測試 (POST) 訊息。POST 訊息說明了系統是否運作正常。



附註：若在按下電源鈕之後，系統仍未啟動，請參閱下一節中啟動失敗之可能原因說明。

除了開機自我測試 (POST) 的訊息外，您還可根據下列情況判斷系統是否處於良好狀態：

- 前面板上的電源指示燈是否亮起。
- 鍵盤上的 Num Lock、Caps Lock 和 Scroll Lock 指示燈是否亮起。

開機問題

在提供電源後，若系統仍無法啟動，請檢查下列可能原因：

- 已連接的外接電源線可能鬆掉了。
- 詳細檢查從電源插座到後面板上電源插孔的電線連接情形。請確認每一條電線都已連接電源。
- 接地電源插座沒有電源。請電機人員檢查電源總開關。
- 內部電纜連接鬆脫或連接錯誤。

檢查內部電纜連接。如果不確定是否可執行這項檢查步驟，請求合格的技術人員協助檢查。



警告！在進行這項檢查工作前，請確認所有電源線均已拔掉。

附註：若你已進行上述的檢查項目，而系統仍



以取得更多的協助。

關閉系統

有兩種關閉工作站的方式，透過軟體或硬體。下列的軟體關閉步驟適用於執行 Windows 作業系統的系統。如需其他作業系統的關閉步驟，請參閱相關的使用者說明文件。

透過軟體關閉系統

1. 同時按下鍵盤上的 <Ctrl> + <Alt> + 鍵或按一下 Windows 工作列上的「開始」。
2. 選擇「關機」。
3. 從下拉視窗中選擇「關機」，然後按一下「確定」。

透過硬體關閉系統

如果無法使用軟體關閉工作站，請按住電源按鈕不放至少四秒鐘。如果少於四秒鐘，只能讓工作站進入暫停模式。

系統故障排除

重新啟動系統

在進行進階的故障排除之前，請先嘗試使用下列方法重新啟動系統。

執行	目的	動作
暖開機	清除系統記憶體，並重新載入作業系統。	按下 <Ctrl> + <Alt> +
冷開機	清除系統記憶體，重新啟動 POST，並重新載入作業系統。本操作將中斷所有週邊設備的電源。	先按下系統電源鍵關閉電源，接著再次按下該鍵重新打開電源。

初始系統啟動故障

初始系統啟動故障常由錯誤安裝或配置所引起。由硬體而導致此故障的可能性較小。如果您遇到的故障和特定應用程式相關，請參閱「軟體程式故障」。

使用下列檢查列表排除故障原因。

- 牆壁上的電源插座是否可使用？
- 電源供應器模組的安裝方式是否正確？
- 系統電源線是否正確插入電源供應器模組的插座？並和 100-120 V 的 NEMA 5-15R 插座或 200-240 V 的 NEMA 6-15R 插座連接？
- 所有的週邊設備纜線是否連接正確並固定？
- 您是否曾按下系統電源鍵開啟工作站（電源指示燈應該亮起綠色）？
- 所有裝置的驅動程式是否安裝正確？
- 硬碟的格式化與組態設定是否正確？
- BIOS 設定公用程式中的 BIOS 組態設定是否正確？
- 作業系統是否正確載入？請參閱作業系統的說明文件。
- 所有的硬體元件是否符合被檢測的元件清單？
- 所有內部纜線是否連接正確並固定？
- 處理器是否完全固定安裝在主機板插槽上？
- 所有處於正確位置，且未接觸任何元件的支架，是否可能引起潛在短路？
- 所有外接擴充卡是否完全固定安裝在主機板插槽上？
- 所有的系統跳線設定是否正確？
- 外接板和週邊裝置上的所有開關設定是否正確？

硬體診斷測試

本章節將提供一種詳細方法，用來確認硬體故障並找出原因。

檢查開機狀態



小心！要將週邊設備纜線從工作站上拔掉前，先關閉系統與所有外接週邊裝置的電源。若未如此，將對系統和 / 或週邊裝置造成永久性損壞。

1. 關閉系統與所有週邊裝置的電源。
2. 除了鍵盤與顯示器外，請拔掉與系統連接的各個裝置纜線。
3. 確認系統電源線二端各插入正確接地的 AC 電源插座，以及電源供應器模組的插孔中。
4. 確認顯示器與鍵盤已正確連接至系統。
5. 打開顯示器。
6. 設定顯示器的亮度與對比度，設定值至少為最大範圍的三分之二。請參閱顯示器隨附的說明文件。
7. 如果要正常從硬碟載入作業系統，請先確認軟碟機中沒有磁片和光碟。
8. 如果電源指示燈亮起，請嘗試從軟碟機啟動。
9. 打開系統電源。

如果控制面板上的電源指示燈不亮，請參閱「電源指示燈不亮」。

檢查儲存裝置的狀態

由於 POST 會確認系統組態，它會測試系統安裝的每個大容量儲存裝置的狀態。當檢查每個裝置時，它的活動指示燈會暫時亮綠燈。檢查硬碟其他已安裝裝置的活動指示燈。

如果這些指示燈都不亮，請參閱「特定故障和相應解決方法」。

確認作業系統的載入

一旦系統啟動，螢幕會出現作業系統的提示。不同作業系統會有不同提示。如果沒出現作業系統提示，請參閱「監視器上沒有出現字元」。

特定故障和相應解決方法

下列為使用工作站過程中，出現的特定故障以及相應的解決方法。

電源指示燈不亮

依下列步驟檢查：

- 確認電源供應器模組安裝正確。
- 確認電源線連接正確。
- 確認牆壁插座有電。您可插入其他裝置確認檢查。
- 確認前面板的電源指示燈亮綠燈。
- 拆下所有外接擴充卡，看看系統是否可啟動。
如果成功重新啟動，再重新裝回擴充卡，每重裝一塊卡就重新啟動系統，檢查是否有那塊卡造成故障。
- 確認安裝的記憶體模組是否為系統相同，並且安裝方式正確無誤。
- 確認安裝的處理器是否為系統相同，並且安裝方式正確無誤。

無法偵測到新安裝的記憶體模組

依下列步驟檢查：

- 確認記憶體模組的規格與系統相容。
- 確認記憶體模組已照指南方式正確安裝。
- 確認記憶體模組已正確安裝於主機板插槽上。

網路連線指示燈不亮

依下列步驟檢查：

- 檢查所有接線和網路設備，確認其狀態正常。
- 重新安裝網路驅動程式。
- 嘗試換接交換機上的其他連接埠或集線器。

網路活動指示燈不亮

依下列步驟檢查：

- 確認系統載入正確的網路驅動程式。
- 網路可能處於閒置狀態。

連接到 USB 連接埠的週邊裝置無法工作

依下列步驟檢查：

- 減少連接到 USB 集線器的外接裝置數量。
- 請參閱裝置隨附的說明文件。

軟體程式故障

依下列步驟檢查：

- 檢查系統軟體組態設定是否正確。
請參閱該軟體的安裝與操作說明文件，了解軟體設定和使用說明。
- 嘗試使用另一版本的軟體，確認是否問題出現在使用的軟體拷貝。如果軟體的其他版本可以正常執行，請聯絡該軟體廠商討論軟體瑕疵事宜。

監視器上沒有出現字元

依下列步驟檢查：

- 鍵盤運作是否正常？檢查方法為：打開和關閉 Num Lock 功能，檢查相應的指示燈是否亮起。
- 監視器是否插電並也打開電源？如果您使用切換器，是否切換到正確的系統了？
- 監視器上的亮度與對比度的設定值是否合適？
- 監視器的訊號線連接是否正確？
- 如果將監視器換接到另一不同系統，監視器運作是否正常？
- 拆下所有外接擴充卡，看看系統是否可啟動。
如果成功重新啟動，再重新裝回擴充卡，每重裝一塊卡就重新啟動系統，檢查是否有那塊卡造成故障。
- 確認安裝的記憶體模組是否為系統相同，並且安裝方式正確無誤。
- 確認安裝的處理器是否為系統相同，並且安裝方式正確無誤。

如果您正在使用外接的視訊控制卡，請執行下列步驟：

1. 檢查監視器是否能使用內建視訊控制卡運作。
2. 檢查外接的視訊控制卡是否完全固定安裝在插槽上。
3. 重新啟動系統，讓變更生效。
4. 如果重新啟動系統後，監視器仍然沒出現任何字元，請再次重新啟動系統。



注意：POST 過程發出的嗶聲 (Beep) 代碼。

如果您需要客服技術支援，需要提供此代碼資訊。

如果 POST 過程沒有任何嗶聲 (Beep) 代碼，

監視器也沒有任何字元，那麼監視器或視訊控制卡可能有問題。

請聯絡您當地的客服或授權經銷商，尋求協助。

注意事項

安全與舒適性的相關資訊

重要安全指示

請仔細閱讀本安全指示，並妥善保管本文件以便日後查詢使用。請務必遵守標示在本產品上的所有警告與指示訊息。

在清潔前請先關閉本產品的電源

請先將本產品從牆上插座拔除後，再進行清理工作。請勿使用液狀或噴霧清潔劑，使用微濕的布擦拭清潔本產品。

接上中斷連線裝置的注意事項

在將電源連接至電源供應器或從電源供應器移除時，請遵守以下指南：

- 在連接電源線到 AC 電源插座之前，請先安裝電源供應器。
- 從電腦移除電源供應器之前，請先拔下電源線。
- 如果系統有多個電力來源，請從電源供應器拔下所有的電源線，以中斷系統電源。

協助工具注意事項

請確認您要接上電源插頭的插座，其位置是盡可能靠近設備操作人員，並且容易使用。當您需要切斷設備的電源時，請確認將電源線從插座上拔下。

警告

- 勿靠近水邊使用本產品。
- 勿將本產品放置在不穩固的平台、支架或桌面上使用。本產品可能因掉落而導致嚴重受損。
- 本產品的插槽和通風孔均做為通風之用，以確保本產品操作的可靠性，並預防過熱，絕不可堵塞或蓋住這些通風孔。請勿將本產品放置在床上、沙發、地毯等類似地點上，因為這樣可能會堵塞通風孔。除非有適當的通風，否則絕對不要將本產品放在靠近電暖爐或暖氣機的地方，或是採用嵌入式的安裝方式。
- 請勿將任何物體從通風槽中插入產品中，因為可能會觸電或造成短路，並導致火災或產生電擊。切勿潑灑任何液體到產品上。

- 請勿將本產品置於易震動的平面上，以避免內部零件的損壞並防止電池液的漏出。
- 在運動、行動或任何震動環境中請勿使用，因為其可能引起突如其來的短電流或是損壞轉輪裝置、硬碟，甚至是鋰電池漏液的危險。

電力使用

- 本產品僅可使用電源線標籤所規定的電壓。若不確定可供使用的電壓種類，請洽詢經銷商或當地的電力公司。
- 請勿在電源線上面放置任何重物。電源線的走線或配置要特別小心，避免放在會被物品或腳絆到的地方。
- 使用延長線時，請注意其電流負荷量。插在同一延長線的電器設備使用電量不可超過延長線的電流負荷量。同時，同一插座的耗電量也不可超過保險絲的負荷量。
- 請勿將電源插座、延長線或插頭與太多裝置連接，以免負荷量過重。整體的系統負載量不得超過分支電路功率的 80%。如果使用的是延長線，則其負載量不應超過延長線輸入功率的 80%。
- 產品隨附的 AC 電源轉換器配備有三線式接地插頭。此插頭僅適合用於與接地插座連接。請在插入 AC 電源轉接器插頭前，確認該插座已接地。請勿將插頭插入一個非接地式的插座。如需詳細資訊，請與電氣技師洽詢。



.....

警告！插頭的接地腳是一個安全防護功能。
在使用電源插座時如果接地不完全，
可能會發生電擊並 / 或造成身體傷害。



.....

注意：接地腳同時提供了良好的保護，避免
鄰近電子裝置對產品性能產生干擾及製造噪音。

僅使用本產品專用電源線組合（隨配件盒附贈的）。此電源線組合屬可分離式：UL 安全規定 / CSA 認證、SPT-2 類、最小功率設定 7 A 125 V、VDE 認可或同等認可。最大的長度為 4.6 公尺（15 呎）。

產品維護

請勿自行維修本產品，因為打開或移除機殼時，會讓您暴露在危險的電壓或

其他風險之中。應由專業合格的維修人員進行維修工作。

當發生下列情形時，請拔掉本產品的電源插頭，並由專業人員進行維修：

- 當電源線或插頭損壞、切開或磨損時。
- 曾有液體潑灑在產品上。
- 產品曾遭雨淋或浸在水中。
- 產品曾經掉落，或機殼已經損壞。
- 產品的效能出現極大的改變，則表示產品需要維修。
- 在遵守操作指示之後產品還是不能正常運作。



備註：請遵照操作指示來進行調整控制，不當的控制調整會損壞產品，使專業合格的維修人員花費更長的時間，才能讓產品恢復正常情形。
本工作站應安置在有限制門禁管理處或同樣妥善位置。



警告：如果電池未正確更換，將有爆炸的危險。
只能更換相同品牌或者製造廠商推薦相同類型的電池。使用過的電池要按照製造廠商的指示加以處理。

HEVC



Advance™

Covered by patents at patentlist.accessadvance.com